

FOREWORD

Thank you for choosing **K9 2400SW(C,F)/K9 2400(D)C/K9 2400F**, the **KIOTI** utility vehicle.

KIOTI is committed to provide the best quality products.

It is strongly recommended for **KIOTI** customer to read this owner's manual thoroughly before using **K9 2400SW(C,F)/K9 2400(D)C/K9 2400F** as the manual contains a lot of valuable information, such as safe driving guide, explanation for operations, maintenance interval, simple maintenance guide, trouble shootings and etc.

If you have any question about the product or manual, please feel free to contact **KIOTI**.
KIOTI is always trying to deliver ultimate satisfaction and safety to customers.



< NOTE >

- Make sure to read this manual carefully and keep it handy for future reference.
- When leasing or transferring this vehicle, deliver this manual together with the vehicle.
- The specifications in this manual are subject to change without notice.

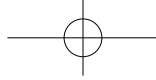

ISO 3600 EU STANDARDS

This manual was compiled in compliance with the ISO 3600, standards and the here contained instructions comply the requirements of the Machinery Directive 2010/52/EU in force in the European Community.

DESCRIPTION	NON CANOPY	CANOPY
1. ROPS (protection against overturning)	Yes	Yes
2. FOPS (protection against objects falling from above)	No	No
3. OPS (protection against penetration of objects from sides) protection against hazardous chemicals	No (Category I)	No (Category I)



TABLE OF CONTENTS

SECTION

■ SAFETY PRECAUTIONS	1
■ VEHICLE IDENTIFICATIONS	2
■ SPECIFICATIONS	3
■ CONTROLS AND FEATURES	4
■ OPERATION	5
■ REPLACEMENT PARTS	6
■ MAINTENANCE	7
■ STORAGE AND DISPOSAL	8
■ TROUBLESHOOTING	9
■ INDEX	10

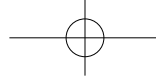

TABLE OF CONTENTS

<p>SAFETY PRECAUTIONS 1-1</p> <p style="padding-left: 20px;">PRECAUTIONS BEFORE OPERATION 1-2</p> <p style="padding-left: 40px;">GENERAL PRECAUTIONS 1-2</p> <p style="padding-left: 20px;">PRECAUTIONS DURING OPERATION 1-4</p> <p style="padding-left: 40px;">WHEN STARTING THE ENGINE 1-4</p> <p style="padding-left: 40px;">WHEN DRIVING THE VEHICLE 1-6</p> <p style="padding-left: 40px;">WHEN PARKING THE VEHICLE 1-14</p> <p style="padding-left: 20px;">SAFETY PRECAUTIONS DURING SERVICING.. 1-15</p> <p style="padding-left: 20px;">SAFETY PRECAUTIONS WHEN USING THE ROPS..... 1-19</p> <p style="padding-left: 20px;">CLEANING THE VEHICLE..... 1-20</p> <p style="padding-left: 20px;">IMPLEMENTS AND ATTACHMENTS 1-21</p> <p style="padding-left: 20px;">EMERGENCY SITUATION 1-21</p> <p style="padding-left: 20px;">SAFETY DECAL..... 1-22</p> <p style="padding-left: 40px;">MOUNTING LOCATION 1-22</p> <p style="padding-left: 40px;">DECALS..... 1-24</p> <p style="padding-left: 40px;">CAUTIONS FOR DECAL MAINTENANCE 1-28</p>	<p>PRECAUTIONS BEFORE OPERATION 2-1</p> <p style="padding-left: 20px;">VEHICLE IDENTIFICATION NUMBER 2-2</p> <p style="padding-left: 40px;">VEHICLE SERIAL NUMBER..... 2-2</p> <p style="padding-left: 40px;">ENGINE SERIAL NUMBER 2-2</p> <p>SPECIFICATIONS 3-1</p> <p style="padding-left: 20px;">SPECIFICATION 3-2</p> <p style="padding-left: 40px;">EXTERIOR DIMENSIONS 3-2</p> <p style="padding-left: 40px;">GENERAL SPECIFICATIONS 3-3</p> <p style="padding-left: 40px;">OPTION LIST AND FEATURES 3-6</p> <p style="padding-left: 40px;">NOISE LEVELS AS PERCEIVED BY THE OPERATOR 3-8</p> <p style="padding-left: 40px;">VIBRATION LEVELS OF THE UTV EXPOSITION TO VIBRATIONS 3-8</p> <p>CONTROLS AND FEATURES 4-1</p> <p style="padding-left: 20px;">EXTERIOR VIEW 4-3</p> <p style="padding-left: 40px;">HOOD 4-4</p> <p style="padding-left: 40px;">ELECTRIC COOLING FAN MOTOR 4-4</p> <p style="padding-left: 40px;">SUSPENSION 4-5</p> <p style="padding-left: 40px;">HEADLAMP 4-5</p>
--	---

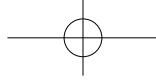

TABLE OF CONTENTS

FRONT HITCH RECEIVER (IF EQUIPPED)	4-5	ENGINE OIL PRESSURE WARNING LAMP	4-20
DRAWBAR (IF EQUIPPED)	4-6	HEAD LIGHT HIGH BEAM LAMP	4-21
REAR HITCH RECEIVER	4-6	PARKING BRAKE INDICATOR	4-21
REFLEX REFLECTOR	4-7	NEUTRAL INDICATOR	4-22
SWITCHES	4-8	SEAT BELT WARNING LAMP (IF EQUIPPED)	4-22
KEY SWITCH	4-8	GLOW PLUG INDICATOR	4-23
COMBINATION SWITCH	4-10	ENGINE CHECK LAMP	4-23
HAZARD LAMP SWITCH	4-12	BATTERY CHARGING LAMP	4-23
WORKING LIGHT	4-13	LOWER FUEL LEVEL WARNING INDICATOR	4-24
HEADLAMP SWITCH	4-13	ERROR INDICATOR	4-25
CARGO BED CONTROL SWITCH (IF EQUIPPED)	4-14	CONTROLS	4-26
SPARE SWITCH PANEL	4-15	SHIFT LEVER	4-26
USB PORT & POWER SOCKET	4-15	ACCELERATOR PEDAL	4-27
INSTRUMENT PANEL	4-17	BRAKE PEDAL	4-27
SPEEDOMETER	4-17	PARKING BRAKE LEVER	4-29
HOURLY METER, ODOMETER	4-18	DIFFERENTIAL LOCK LEVER (REAR WHEEL)	4-30
MODE SELECTION BUTTON	4-18	2WD/4WD SHIFT LEVER	4-31
ADJUSTING THE TIME	4-18	SEAT	4-31
FUEL GAUGE	4-19	SEAT BELT	4-32
COOLANT TEMPERATURE GAUGE	4-19	HEADREST (IF EQUIPPED)	4-33
TURN SIGNAL LAMP	4-20	PASSENGER SEAT	4-33



TABLE OF CONTENTS

ROPS	4-34	AIR CONDITIONER SWITCH (AIR CONDITIONER) 4-45	
BRUSH GUARD	4-35	TEMPERATURE CONTROL SWITCH (AIR CON- DITIONER).....	4-45
SKID PLATES (STEEL) (IF EQUIPPED).....	4-35	TEMPERATURE CONTROL SWITCH (HEATER).....	4-47
CUP HOLDERS AND STORAGE BOXES	4-35	CIRCULATION OF INDOOR AIR AND INFLOW OF EXTERNAL AIR	4-48
CARGO BED	4-36	TIRE	4-48
FUEL TANK	4-36	PROPER INFLATION PRESSURE	4-50
HAND THROTTLE LEVER (OPTION).....	4-37	OPERATION	5-1
ENGINE INSPECTION	4-37	PRE-OPERATION	5-2
COOLANT, BRAKE FLUID AND ELECTRICAL DEVICES.....	4-38	DAILY INSPECTION.....	5-2
CABIN SYSTEM.....	4-39	OPERATING THE ENGINE	5-2
INTERIOR DEVICES	4-39	STARTING THE ENGINE.....	5-2
ENTRANCE	4-40	CHECKING WARNING LAMPS AFTER START- ING ENGINE	5-5
FRONT WINDOW	4-40	OPERATING PRINCIPLE OF PREHEAT SYSTEM	5-6
WIPER	4-41	STOPPING THE ENGINE	5-6
INDOOR LAMP	4-42	OPERATING THE VEHICLE	5-7
SUN VISOR (IF EQUIPPED)	4-42	HOW TO DRIVE.....	5-7
VENT.....	4-42	WARMING UP	5-10
INSIDE REAR VIEW MIRROR (IF EQUIPPED).....	4-43		
HEATER AND AIR CONDITIONER	4-44		
FAN SPEED CONTROL DIAL.....	4-45		

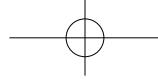

TABLE OF CONTENTS

JUMP START	5-11	ESSENTIAL REPLACEMENT PART	6-2
STOPPING	5-12	OILS AND FLUID	6-2
PARKING	5-13	FILTERS	6-2
SHIFTING	5-14	BELTS AND RUBBER PARTS	6-3
DRIVING ON SLIPPERY SURFACES	5-14	ELECTRIC PARTS	6-3
TURNING	5-15	MAINTENANCE.....	7-1
DRIVING ON SLOPE.....	5-16	MAINTENANCE CHECK LIST.....	7-3
DRIVING IN FOREST.....	5-17	DAILY CHECK CHART	7-3
DRIVING THROUGH WATER.....	5-18	MAINTENANCE INTERVAL TABLE	7-4
DRIVING BACKWARD	5-19	LUBRICANTS.....	7-6
DRIVING ON ROAD	5-19	DAILY INSPECTION	7-8
TRANSPORTING CARGO.....	5-20	ACCESS FOR SERVICE.....	7-8
CAUTIONS WHEN USING ELECTRIC POWER		OPENING INSPECTION SHIELD (A)	7-8
STEERING.....	5-22	OPENING SEAT CUSHION (B)	7-9
UNLOADING	5-23	RAISING CARGO BED (C)	7-9
TOWING TRAILER	5-24	APPLYING GREASE (D).....	7-10
TRANSPORTING.....	5-25	CHECKING ENGINE OIL LEVEL (E)	7-12
4WD OPERATION	5-26	CHANGING ENGINE OIL AND FILTER (F)	7-13
DIFFERENTIAL LOCK OPERATION	5-27	DUST VALVE (G)	7-14
TAILGATE (BACK DOOR).....	5-28		
REPLACEMENT PARTS	6-1		

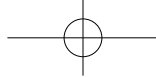

TABLE OF CONTENTS

REPLACING AIR FILTER (H).....	7-15	CHECKING BRAKE PEDAL FREE PLAY (Y)	7-34
CHECKING AIR HOSE AND CLAMP(I).....	7-15	CHECKING BRAKE PAD (Z).....	7-35
CHECKING CVT BELT (J).....	7-16	CHECKING PARKING BRAKE (AA).....	7-36
CHECKING CVT DRIVEN PULLEY CLUTCH BUTTONS (K)	7-18	ADJUSTING SUSPENSION (AB).....	7-37
CHECKING FUEL FILTER(L).....	7-19	CHECKING SUSPENSION SHOCK ABSORBER (AC).....	7-38
BLEEDING FUEL LINE (M).....	7-20	BATTERY (SEALED) (AD).....	7-38
CHECKING INJECTION NOZZLE AND FUEL INJECTION PUMP (N)	7-21	REPLACING HEADLAMP BULB (AE).....	7-42
CLEANING RADIATOR CORE (O).....	7-21	CHECKING AND REPLACING FUSE (AF).....	7-42
CHECKING COOLANT IN AUXILIARY COOLANT TANK (P).....	7-22	MAIN FUSE (SLOW-BLOW FUSE) (AG)	7-44
CHANGING COOLANT (Q1).....	7-23	ALIGNING WHEEL AND CHECKING WHEEL NUT (AH).....	7-44
BLEEDING AIR IN COOLANT(Q2).....	7-26	CHECKING DIFFERENTIAL LOCK CABLE (AI).....	7-45
CHECKING SPARK ARRESTER OF EXHAUST PIPE (IF EQUIPPED) (R).....	7-27	CHECKING SHIFT AND 4WD CABLES (AJ).....	7-45
CHECKING AND CHANGING GEARBOX OIL (S)....	7-27	USING BIODIESEL (AK).....	7-46
CHECKING AND CHANGING FRONT AXLE OIL (T) ..	7-29	ADJUSTING BELT TENSION (AL)	7-46
CHECKING AND CHANGING REAR AXLE OIL (U)....	7-31	WASHING (AM).....	7-47
CHECKING DRIVE SHAFT AND CV BOOTS (V).....	7-32	PROTECTING PLASTIC AND PAINTED SUR- FACE (AO)	7-48
CHECKING STEERING RACK BOOTS AND BALL JOINT (W)	7-33	CHECKING HYDRAULIC OIL (AP)	7-48
CHECKING BRAKE FLUID (X).....	7-34	CLEANING AIR CONDITIONER CONDENSER (AQ) ..	7-49
		CHECKING REFRIGERANT (AR).....	7-49

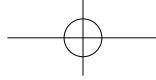
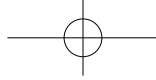

TABLE OF CONTENTS

AIR CONDITIONER MAINTENANCE (AP).....	7-49
REPLACING A/C FILTER(AQ).....	7-50
AIR CONDITIONER BELT TENSION (AR).....	7-51
STORAGE AND DISPOSAL.....	8-1
VEHICLE STORAGE	8-2
DAILY STORAGE.....	8-2
LONG-TERM STORAGE.....	8-2
USING VEHICLE AFTER LONG-TERM STORAGE ...	8-3
DISPOSAL	8-4
TROUBLESHOOTING	9-1
VEHICLE TROUBLESHOOTING	9-2
INDEX.....	10-1



SAFETY AND VEHICLE DAMAGE WARNING

This manual includes information titled as **WARNING**, **CAUTION**, **IMPORTANT** and **NOTE**. These titles indicate the following:



This indicates that a condition may result in harm, serious injury or death to you or other persons if the warning is not heeded. Follow the advice provided with the warning.



This indicates that a condition may result in damage to your vehicle or its equipment if the caution is not heeded. Follow the advice provided with the caution.



This mark indicates emphasis on notable characteristics of working procedures, and information about technology for easier operation.



This indicates that interesting or helpful information is being provided.



UNIVERSAL SYMBOLS

Various universal symbols have been used on the instruments and controls of your **KIOTI** vehicle. Below is a list of the universal symbols and their meanings.

 EPS Error

 Differential Lock, Front

P Parking

 Parking Brake

 Differential Lock, Rear

N Neutral Position

 Battery Charging Condition

 Four-Wheel Drive-ON

H High speed travel light

 Engine Oil-Pressure

 Headlight-High Beam

L Low speed travel light

 Turn Signal

 Preheat

R Reverse travel light

 Engine Check

 Seat Belt

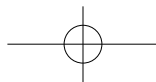
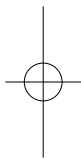
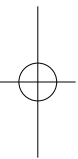



SAFETY PRECAUTIONS

1

1

- PRECAUTIONS BEFORE OPERATION 1-2**
 - GENERAL PRECAUTIONS 1-2
- PRECAUTIONS DURING OPERATION 1-4**
 - WHEN STARTING THE ENGINE 1-4
 - WHEN DRIVING THE VEHICLE 1-6
 - WHEN PARKING THE VEHICLE 1-14
- SAFETY PRECAUTIONS DURING SERVICING ... 1-15**
- SAFETY PRECAUTIONS WHEN USING THE ROPS.... 1-19**
- CLEANING THE VEHICLE..... 1-20**
- IMPLEMENTS AND ATTACHMENTS..... 1-21**
- EMERGENCY SITUATION 1-21**
- SAFETY DECAL..... 1-22**
 - MOUNTING LOCATION 1-22
 - DECALS 1-24
 - CAUTIONS FOR DECAL MAINTENANCE 1-28



PRECAUTIONS BEFORE OPERATION

GENERAL PRECAUTIONS

A careful operator is the best operator. Most accidents can be avoided by observing certain precautions. To help prevent accidents, use these safety precautions, and pay attention to the job at hand. If you can prevent an accident, your time will have been well spent.

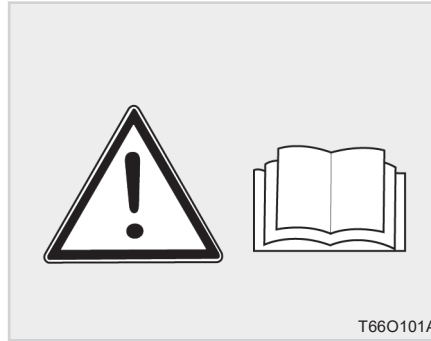

1. It is recommended that you read and understand this entire manual before operation of your new vehicle. Failure to do so could result in accidents or injury.
2. Only persons who are properly trained should be allowed to operate the vehicle.
3. Read and follow all warning labels and decals affixed to the vehicle.

4. Replace any missing or damaged decals as soon as it is practical. A list of decals is shown on page 1-22~27.
5. Keep safety decals clean of dirt and debris.

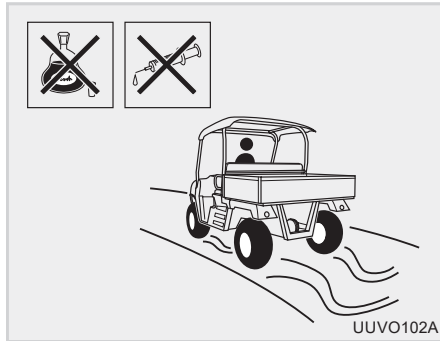

6. Never operate this vehicle or any other agricultural equipment while under the influence of alcohol, drugs or while fatigued.
7. While working in cooperation with other vehicles always communicate your intentions.

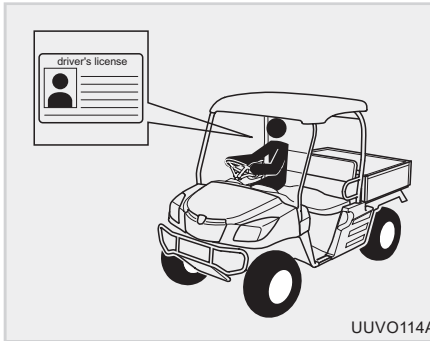

8. This vehicle should be driven only by a driver with a valid driver's license.

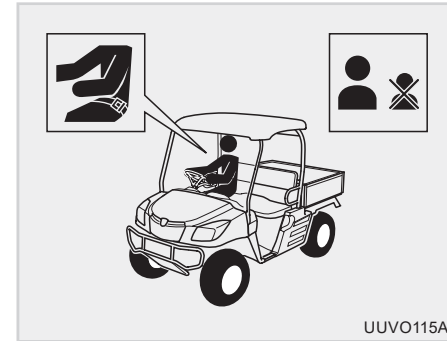

9. Never let anyone under 5 years of age ride in the vehicle. If it is unavoidable, such child should be secured with special restraints which are not available with this vehicle. Both driver and passengers should wear their seat belts at all times.



PRECAUTIONS DURING OPERATION WHEN STARTING THE ENGINE

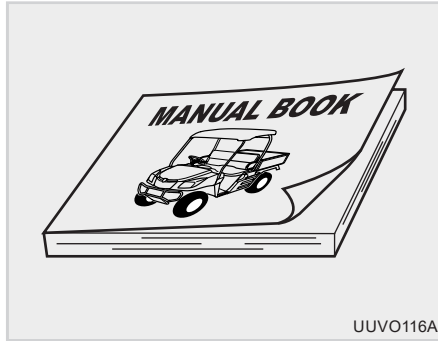

10. Never allow anyone to operate this vehicle unless person has read this manual and all decals thoroughly.

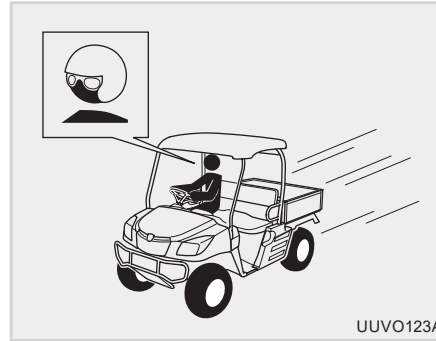

11. It is recommended to wear a helmet whenever driving this vehicle in an aggressive manner. Eye protection is recommended at all times.

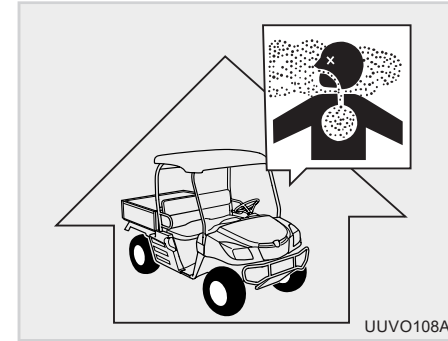

1. Do not operate your vehicle in an enclosed building without the proper ventilation. Inhalation of carbon monoxide can cause serious injury or death.

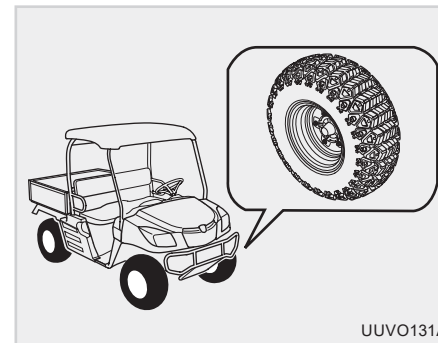
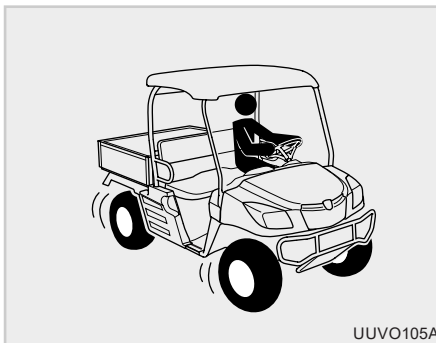
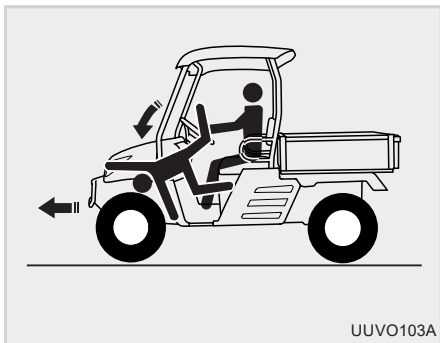

1

2. When starting the vehicle make sure your path is clear of people to avoid accidents caused by sudden movements.
3. Before starting your vehicle you should make sure that all shift levers are in the neutral position and parking brake is applied.

4. Never start the engine while not seated.
5. Keep bystanders away from the vehicle while in operation.
6. Be sure to scrape off mud or soil from your shoes before riding in the vehicle.

7. Make sure that wheel nuts have been tightened to the specified torque.
8. Always check the tire pressure before start engine. For more information about tire pressure, see chapter 4.
9. Make sure that all pressure lines are tight before starting the vehicle.



WHEN DRIVING THE VEHICLE



10. Always activate the brake pedal before releasing the park brake.



1. In some countries or states, it is illegal to drive a UTV on public roads. Be aware of traffic laws before driving.

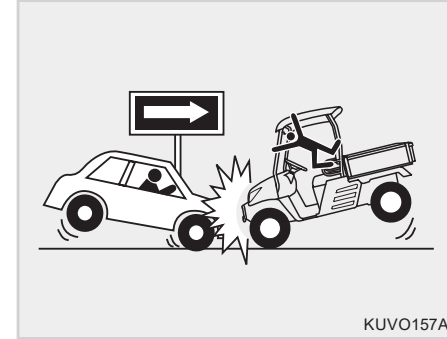

2. When driving on a public road, make sure to install the "Safety lamp kit" supplied by **KIOTI** and observe the applicable regulations and laws. If the vehicle is not equipped with the "Safety lamp kit", there will be no brake lamps, turn signal lamps and tail lamps on the vehicle. In this condition, it is very dangerous to drive on a public road.

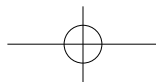

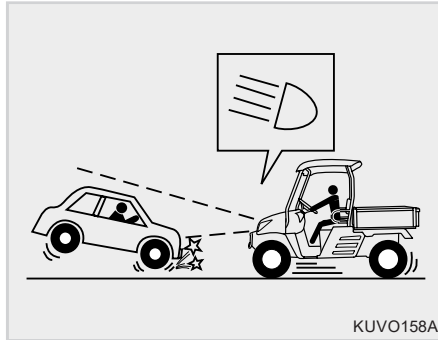

3. While turning the headlights on, dim them when meeting another vehicle.



4. Always slow the vehicle before turning. Turning at high speed may tip the vehicle over or cause a loss of control.

5. Drive at speeds that allow you to maintain control at all times.



6. Do not apply the differential lock while traveling at road speeds. As the vehicle may run out of control.

7. Do not use 4WD while traveling at road speeds in a normal road condition.

8. Avoid sudden movements of the steering wheel as this can cause a loss of control of the vehicle. This risk is especially great when traveling at road speeds.



9. When working in groups, always let the others know what you are going to do before you do it.
10. Do not operate near ditches, holes, embankments, or other terrain features which may collapse under the vehicle's weight. The risk of vehicle upset is even higher when the ground is loose or wet.

11. Watch where you are going at all times so that you are able to avoid obstacles that can cause injury or damage to your vehicle.
12. Before making reverse movements with your vehicle, you should always check to see that the path is clear.

13. For your safety **ROPS** with a seat belt is recommended for all applications.



1

14. Watch front and rear to avoid obstacles at row ends, near trees and around other obstructions.

15. Never try to get on or off a moving vehicle.

16. To minimize the risk of a rollover crash, be especially careful when obstacles and slopes are ahead and when braking on hills or during turns.

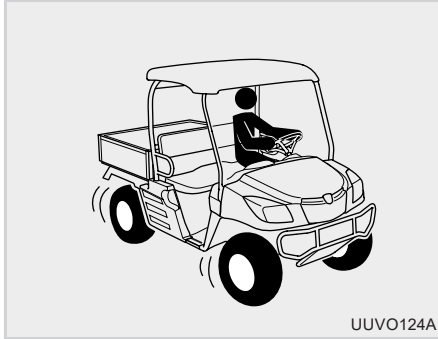

17. Never drive the vehicle at excessive speeds. Always travel at speed proper for the terrain, visibility and operating conditions.



18. Never attempt abrupt wheelies, jumps or other stunts.

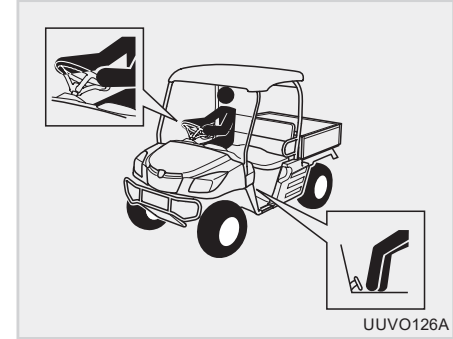

19. Always keep your both hands on the steering wheel and your both feet on the floor of the vehicle during operation.

20. Always keep arms and legs inside the cab frame while the vehicle is in motion.

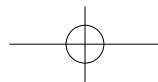

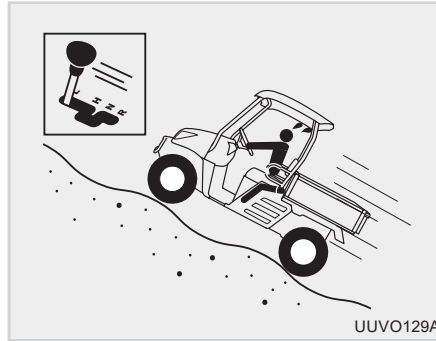

1

21. Never drive in excessively rough, slippery or loose terrain.
22. Never operate on excessively steep hills, relying on this vehicle's or your abilities. Practice on smaller hills before attempting larger hills.

23. Always follow proper procedures for climbing hills as described in this manual. Check the terrain carefully before attempting to climb any hill. Never climb hills with excessively slippery or loose surfaces. Never open the throttle suddenly or make sudden gear changes. Never go over the top of any hill at high speed.

24. When driving on a road inclined vertically or sideward, make sure to drive at a low speed. Otherwise, the vehicle can roll over, leading to a serious accident.
25. Driving with excessive load on a slope can lead to overturn.



UUVO110A

26. Always be careful of skidding or sliding. On slippery surfaces such as ice, travel slowly and exercise caution to reduce the chance of skidding or sliding out of control.

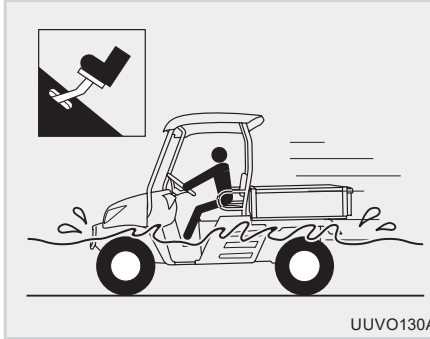

UUVO130A

27. Never operate your vehicle in fast-flowing water or in water deeper than that specified in this manual. Wet brakes may have reduced stopping ability. Test your brakes after leaving water. If necessary, apply them lightly several times to let friction dry out the pads.



UUVO132A

28. Never exceed the stated load capacity for this vehicle. Cargo should be properly distributed and securely attached. Reduce speed and follow the instructions in this manual for hauling cargo or pulling a trailer. Allow a greater distance for braking.

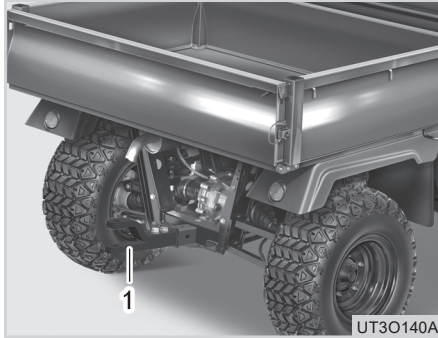

(1) Rear Hitch Receiver

29. Pull only from the rear hitch receiver. Pulling from any other location can cause the damage of vehicle.

⚠ WARNING

- **Never hitch anything to the axle housing or main frame except the hitch receiver.**
- **Pulling from any other location only increases the risk of serious personal injury or death.**

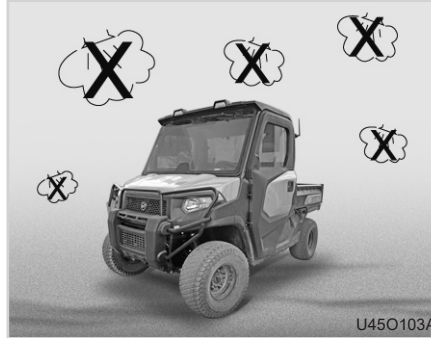

30. This cabin is not certified for chemical proof, never operate the vehicle for chemical spray or in the air contaminated by any chemical or equivalent.

⚠ WARNING

- **This cabin is not designed for spraying chemicals and can not block polluted outside air from entering. Never drive the vehicle in these areas.**

⚠ WARNING

This cab category does not provide protection against hazardous substances;

- *The vehicle fitted with such a cab shall not be used under conditions requiring protection against hazardous substances.*
- *The information of the PPP (Personal Protective Equipment & against Poison) manufacturer (given on the label) shall be followed."*

1

WHEN PARKING THE VEHICLE

⊕ IMPORTANT

How to reduce the risk of exposure to hazardous substances;

- Personal protective equipment (PPE)
- Training and education
- Keeping used PPP out of the cab
- Removing contaminated shoes or clothing before entering the cab
- Keeping cab interior clean
- Disposal of filter(s)
- Following instructions provided by PPE(*), PPP(**), delivery and filtration system and vehicle

(*) - Personal Protective Equipment

(**) - Personal Protective equipment & (against) Poison

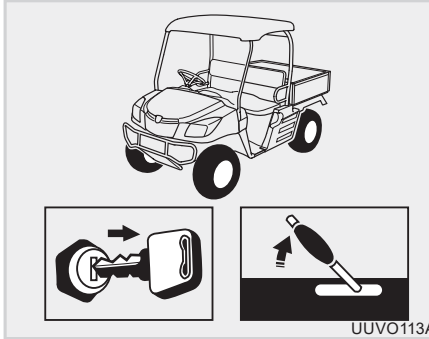

1. Place all control levers in the neutral position, set the parking brake, stop the engine.

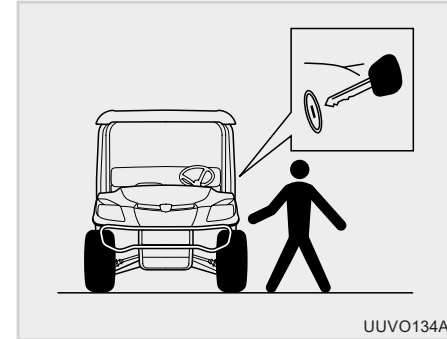

2. Always remove the ignition key when the vehicle is not in use to prevent unauthorized use or accidental starting.

3. Never leave the vehicle without setting the parking brake and shutting off the vehicle.



SAFETY PRECAUTIONS DURING SERVICING

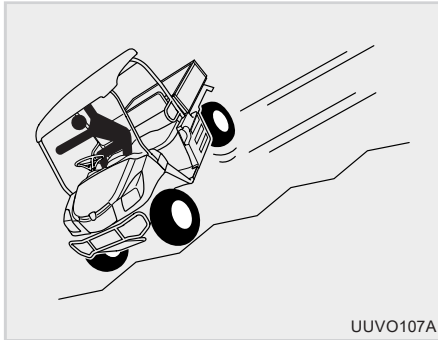

1

4. Never park on a slope with only the transmission engaged. The vehicle may roll down, leading to an accident.
5. If it is unavoidable to park on a slope and leave the vehicle, apply the parking brake and chock the wheels.
6. Never park the vehicle on a steep slope. A serious accident can occur.

1. In order to service your vehicle you must park it on a flat level surface, set the parking brake, place the gear shift lever in neutral and stop the engine.

2. Do not smoke while working around the battery or when refueling your vehicle. Keep all sparks and flames away from the battery and fuel tank. The battery presents an explosive hazard because it gives off hydrogen and oxygen especially when recharging.

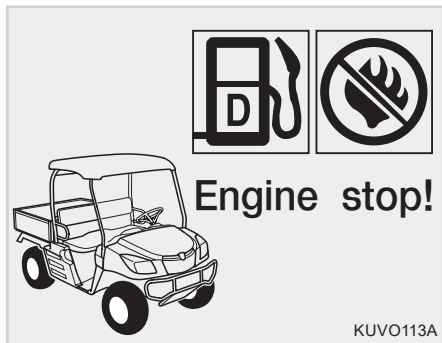

3. You must always stop the engine before refueling the vehicle. Avoid overfilling the vehicle or spilling the fuel.

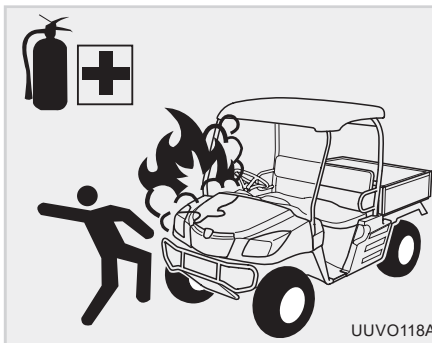

4. It is recommended to keep a first aid kit and fire extinguisher handy at all times.

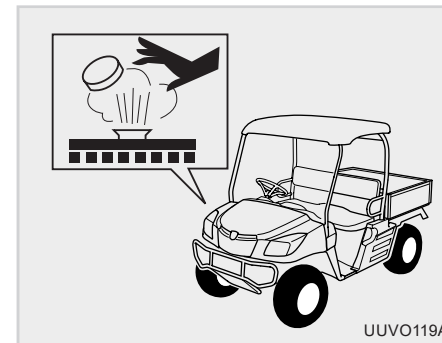

5. Do not remove the radiator cap while the coolant is hot. When cool, slowly rotate the cap to the first stop and allow sufficient time for excess pressure to escape. After all the pressure is released remove the cap completely. If your vehicle is equipped with a coolant recovery tank, add coolant there rather than to the radiator.

6. Allow the vehicle time to cool off before servicing any part that may have become hot while the vehicle was running.

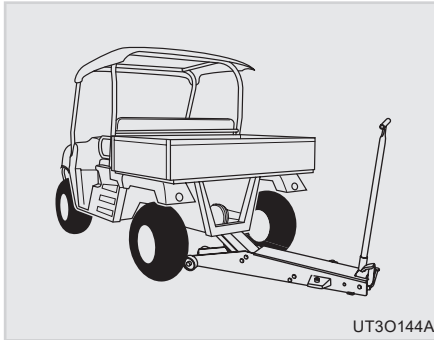
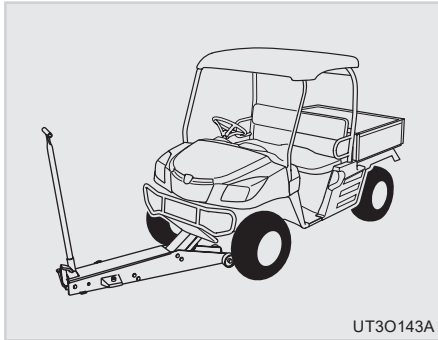
**NOTE**

- Apply the jack lift to the lifting points according to the type of operation and following the safety procedures given before.

1

7. If the UTV must be lifted for servicing, take it to a suitably equipped workshop.
8. Carry out the following operations before any operation about the UTV: Engage the four-wheel drive, the first gear and the parking brake and put chocks to the wheels touching the ground.
9. Before lifting the UTV, avoid its swinging by means of wooden wedges applied to the front axle
10. Use jack lifts of suitable capacity and apply them at the centre of the front and rear axles and paying due attention to weight distribution.
11. No decals for the lifting point are applied on the UTV, as they would be, too difficult to apply in the available spaces and would be all too easily removed or effaced during normal operation of the UTV.

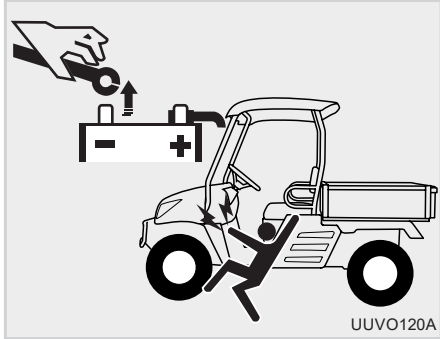

12. When working with your vehicles electrical components, you must first disconnect the battery cables.
13. To ensure that there are no accidents from sparks you must first disconnect the negative battery cable.
14. For jump starting a dead battery, read and follow all of the instructions. (Page 5-11)



15. Tire mounting should be done by qualified professionals, with the proper equipment.
16. Maintaining correct tire pressure is important for the life of your tires. Do not inflate the tires above the recommended pressure specified in the owner's manual.
17. Securely support the vehicle when changing wheels.

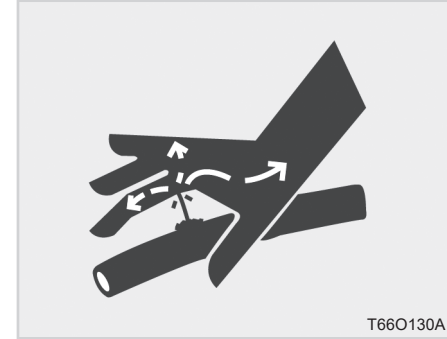

18. Fluid escaping from pinholes may be invisible. Do not use hands to search for suspected leaks; Use a piece of cardboard or wood, instead. Use of safety goggles or other eye protection is also highly recommended. If injured by escaping fluid, see a medical doctor at once. This fluid can produce gangrene and/or severe allergic reaction.



SAFETY PRECAUTIONS WHEN USING THE ROPS

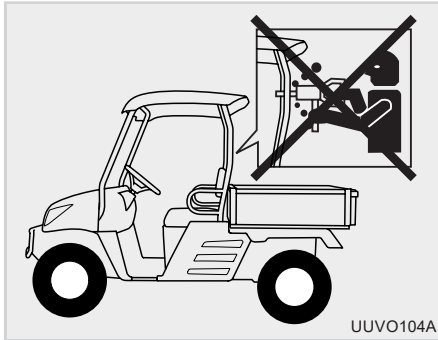

19. No alterations should be made to your **KIOTI** vehicle.



20. Keep environmental pollution in mind. When replacing coolant or oil, dispose of it the right way.
Be sure to observe all relevant regulations when you dispose of the engine oil, transmission oil, fuel, coolant, filters and battery.



(1) ROPS

1. **ROPS** (Roll Over Protective Structure) is equipped to protect driver and passengers when the vehicle is rolled over. Always fasten your seat belt.
Failure to fasten your seat belt can invalidate **ROPS**.

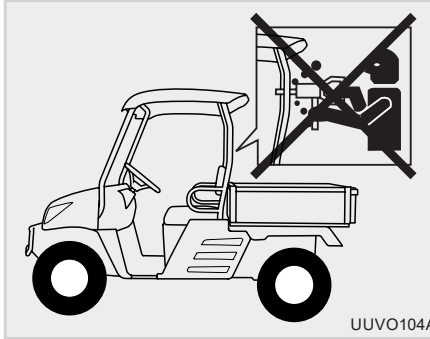

⊕ IMPORTANT

- **ROPS, Sun canopy or cabin are not a FOPS (Falling Object Protective structure).**

It never can protect the riders against falling objects.

Avoid driving the vehicle into a dangerous area such as falling rocks zone.

A **ROPS** should never be modified by welding, grinding or cutting, as this can weaken the **ROPS** structure. If any components of the **ROPS** unit is damaged, it must be replaced.

If the **ROPS** unit is removed or loosened for any reason, the parts should be fitted back to their original positions and all bolts should be properly torqued.

CLEANING THE VEHICLE

- Keep work surfaces and engine compartments clean.
- Before cleaning the machine, always lower implements to the ground, engage the first gear, engage the parking brake, turn the engine off and remove the key.
- Always use specific personal safety devices for each service operation.
- Clean steps, pedals and floor. Remove grease or oil. Brush away dust or mud. In winter, scrape away snow and ice. Remember - slippery surfaces are dangerous.
- Avoid using petrol, paraffin, paint thinner etc. when cleaning plastic parts, e.g.; console, instrument cluster, monitors and gauges etc. Use **ONLY** water, mild soap and a soft cloth when you clean these parts. Using petrol, paraffin, paint thinner etc., will cause cracking or deformation of the part being cleaned.
- Remove and put away any tools, buckets, chains and hooks.



IMPLEMENTS AND ATTACHMENTS

- Hitch loads to the drawbar only. Towing or attaching to other locations may cause the vehicle to overturn.
- Improper use of the drawbar, even if correctly positioned, can cause a rear overturn.
- DO NOT overload an attachment or towed equipment. Use proper counterweights to maintain vehicle stability. Hitch heavy loads to the drawbar only.
- Check for correct coupling between tow hook and trailer. See the Towing Attachments section.
- Use ballast weight as recommended. NEVER add more ballast to compensate a higher load than allowed. Reduce load.

EMERGENCY SITUATION



(1) Emergency Exit Label

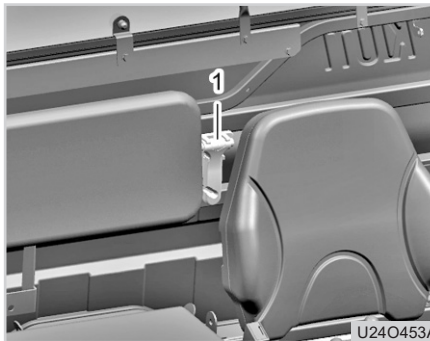

(1) Emergency Hammer

Emergency Hammer is equipped for emergency situation like overturn. Use this hammer to break the glasses for the escaping from vehicle.

1

SAFETY DECAL MOUNTING LOCATION

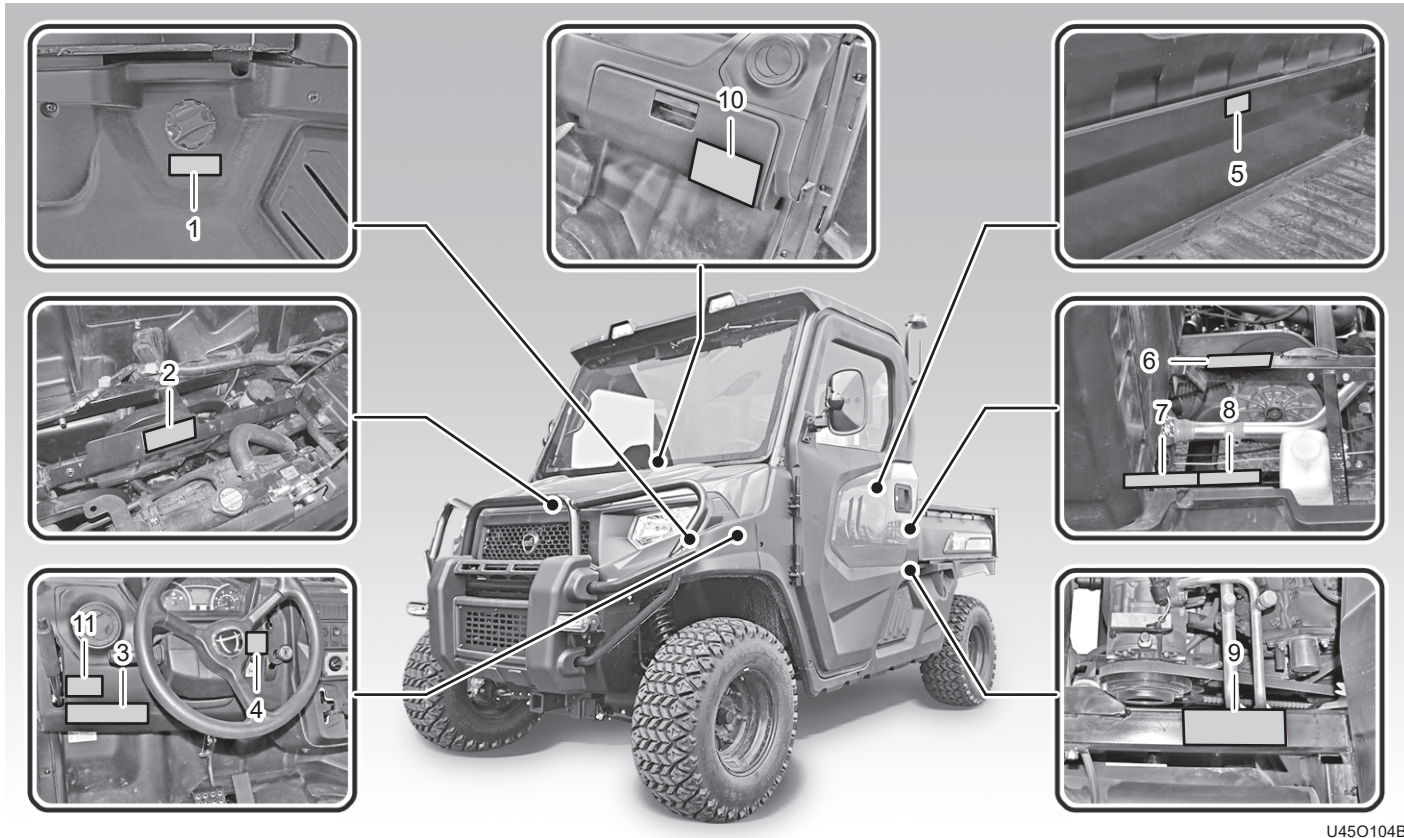



DECALS

(1) Part No. : TC26-0388

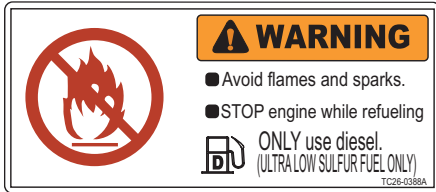

(2) Part No. : T4625-52351



(4) Part No. : UD27-7007

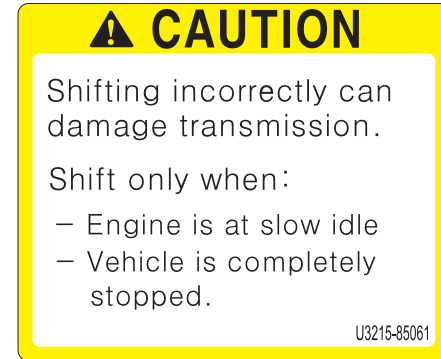

(3) Part No. : U3210-85862

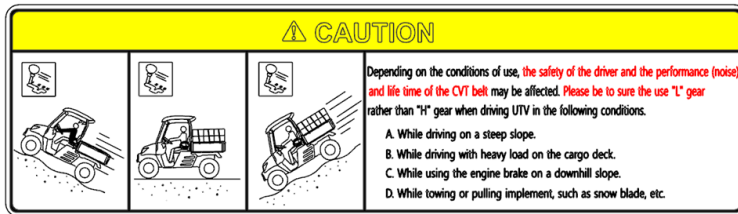

(5) Part No. : UD27-7013

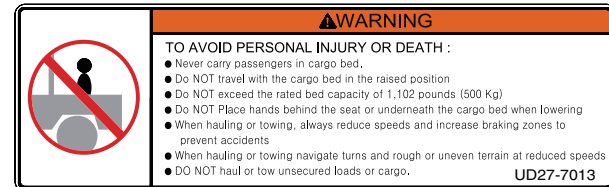



(6) Part No. : UD27-7009



(7) Part No. : UD3215-85701

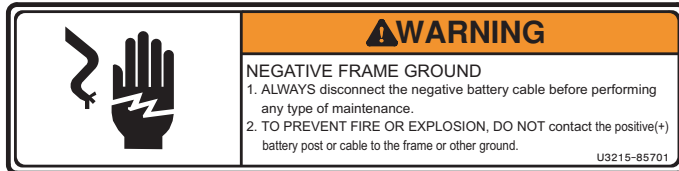

(8) Part No. : U3215-85671

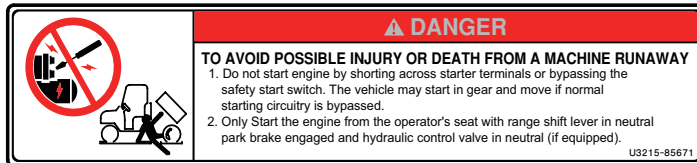

(9) Part No. : U3215-85655



1

(10) Part No. : UD27-7045

WARNING

Improper Use of Off-Highway Vehicles Can Cause Severe Injury or Death

Be Prepared

- Fasten seat belts.
- Wear an approved helmet and protective gear.
- (Reserved for message about other occupant restraint devices.)
- Each rider must be able to sit with back against seat, feet flat on floor [and foot rests], and hands on steering wheel or handhold(s), where equipped. Stay completely inside the vehicle.

Drive Responsibly

Avoid loss of control and rollovers:

- Avoid abrupt maneuvers, sideways sliding, skidding, or fishtailing, and never do donuts.
- Slow down before entering a turn.
- Avoid hard acceleration when turning, even from a stop.
- Plan for hills, rough terrain, ruts, and other changes in traction and terrain.
- Avoid paved surfaces.
- Avoid side hilling (riding across slopes).

Be Sure Riders Pay Attention and Plan Ahead

If you think or feel the vehicle may tip or roll, reduce your risk to injury:

- Keep a firm grip on the steering wheel or handholds and brace yourself.
- Do not put any part of your body outside of the vehicle for any reason.

Require Proper Use of Your Vehicle

Do your part to prevent injuries:

- Do not allow careless or reckless driving.
- Make sure operators are 16 or older with a valid driver's license.
- Do not let people drive or ride after using alcohol or drugs.
- Do not allow operation on public roads (unless designated for off-highway vehicle access) collisions with cars and trucks can occur.
- Do not exceed seating capacity. [X] passenger[s]

[Locate and] Read [Owner's Manual] Follow All Instruction and Warnings [Reserved for Reference to Other Sources of Safety Information]

DRIVER UNDER 16

UD27-7045

(12) Part No. : UD27-7083

WARNING

TO AVOID PERSONAL INJURY OR DEATH:

1. Do not Remove the Roll-Over Protective Structure (ROPS) for any reason.
2. Do not try to modify or repair ROPS. Welding, grinding, drilling or cutting any portion of the ROPS will weaken the structure and prohibit adequate roll-over protection.

UD27-7083

(13) Part No. : U3230-85581

WARNING

1. ROPS like Roll-bar, Sun canopy or cab are not a FOPS falling object protective structural.
2. It can not protect the operator against falling object.
3. Avoid driving the vehicle into or working in a dangerous area such as falling rocks zone.
4. In addition, this vehicle does not provide the safety feature for OPS and prevention of contact with hazardous substances.

U3230-85581

(11) Part No. : UD27-7003

WARNING

TO AVOID PERSONAL INJURY:

Always fasten your seat belt

UD27-7003



(14) Part No. : U3215-8566

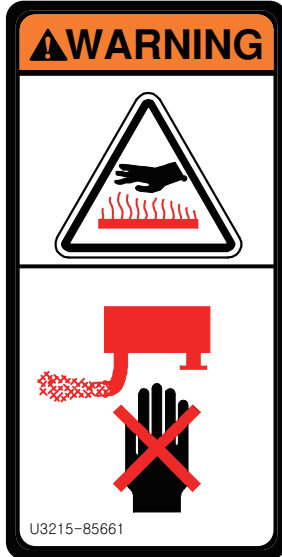

(15) Part No. : T41255-56121

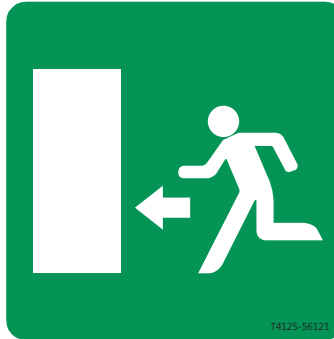

(17) Part No. : TB36-1183

CATEGORY 1

“CATEGORY 1 according to EN 15695-1:2009” when the cab does not provide a specified level of protection against hazardous substances

TB36-1183

1

(16) Part No. : UD27-7117

NOTICE

- Requirements under standard EN 15694:2009 (Agricultural and forestry tractors. Passenger seat. Requirements and test procedures) are met with relevant documentation included in the information document:with relevant documentation included in the information document:
- For engine maintenance remove the seat and maintenance cover.
- Refer to the manual for grease inlet.

UD27-7117

CAUTIONS FOR DECAL MAINTENANCE

Safety decals are attached to the vehicle for safe operation. Make sure to follow the instruction on the decals as well as the following instruction:

CAUTION

- **Keep the decals clean and intact. If any decal is dirty, wash it with soap and dry with a soft cloth.**
- **Never use a solvent, such as thinner or acetone, since it can ruin the decals.**
- **Do not spray high-pressure water directly onto the decal. The decal may fall off the vehicle.**

IMPORTANT

- **If a decal is damaged or lost, contact your local KIOTI dealer immediately to install a new decal.**
- **Make sure to attach the decal to the correct position cleanly without bubbles after cleaning its mounting surface.**
- **If a decal is attached to a component to be replaced, replace the decal as well.**



PRECAUTIONS BEFORE OPERATION

VEHICLE IDENTIFICATION NUMBER 2-2
 VEHICLE SERIAL NUMBER 2-2
 ENGINE SERIAL NUMBER 2-2

2

2



VEHICLE IDENTIFICATION NUMBER VEHICLE SERIAL NUMBER ENGINE SERIAL NUMBER



U45O201B

(1) Vehicle Serial Number

This vehicle serial number is located on the structure frame beside front wheel where is the front right side.



U45O202B

(1) Engine Serial Number

The engine serial number is stamped on the engine cylinder block where the injection pump is installed.

Have the vehicle serial number and engine serial number with you when ordering parts or asking for service information.

Fill in the following boxes with appropriate information as the vehicle serial number and engine serial number should be submitted to the dealer during service.

• **Vehicle Serial No.**

• **Engine Serial No.**

• **Date of Purchase**

To be filled in by purchaser

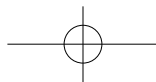



SPECIFICATIONS

SPECIFICATION 3-2

EXTERIOR DIMENSIONS 3-2

GENERAL SPECIFICATIONS 3-3

OPTION LIST AND FEATURES 3-6

NOISE LEVELS AS PERCEIVED BY THE OPERATOR 3-8

VIBRATION LEVELS OF THE UTV EXPOSITION TO VI-
BRATIONS 3-8

3

3



SPECIFICATION EXTERIOR DIMENSIONS

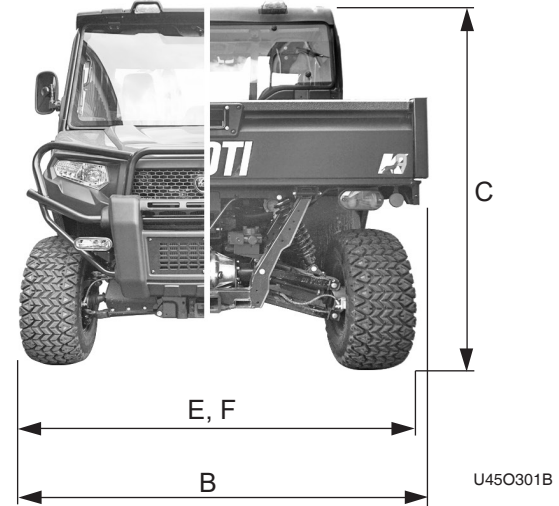
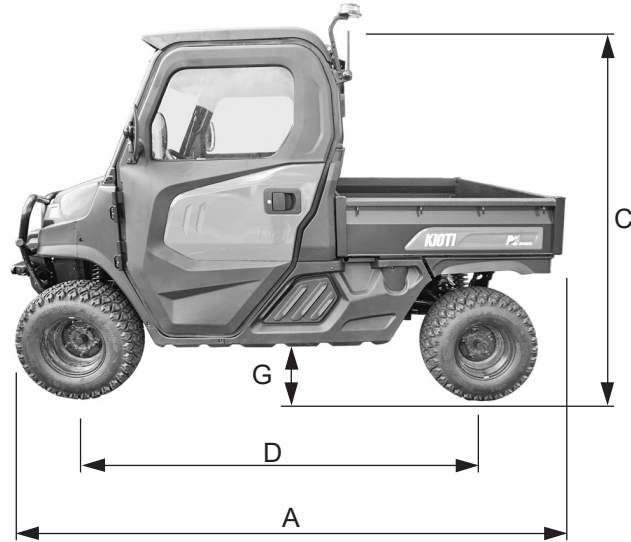

in. (mm)

Overall length (A)	Overall width (B)	Overall height (C)	Wheel base (D)	Front wheel tread (E)	Rear wheel tread (F)	Ground clearance (G)
119.9 (3,045)	64.6 (1,640)	78.3 (1,990)	85.8 (2,180)	51.2 (1,320)	51.2 (1,320)	10.4 (265)

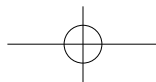



GENERAL SPECIFICATIONS

ITEMS		K9 2400SWC	K9 2400SWF	K9 2400C-EU	K9 2400F-EU	K9 2400DC-AU
Engine	Model	3C100LFU-U3	3C100LFU-U3	3C100LWU-D3	3C100LWU-D3	3C100LWU-D3
	Number of cylinders	3				
	Total displacement	cc(cu in.)	1,007 (61.45)			
	Fuel	Diesel				
	Gross	HP(kW)	24.5 (18.3)			
	Rated revolution	rpm	3,200			
Capacity	Engine oil	U.S.Gal. (L)	0.85 (3.2)			
	Fuel tank	U.S.Gal. (L)	9.8 (37.0)			
	Gear box oil	U.S.Gal. (L)	0.24 (0.9)			
	Front differential case oil	U.S.Gal. (L)	0.16 (0.6)			
	Rear differential case oil	U.S.Gal. (L)	0.21 (0.8)			
	Coolant	U.S.Gal. (L)	1.45 (5.5)			
Driving unit	Main shift	CVT (Continuous Variable Transmission with belt)				
	Range shift	High / Low / Neutral / Reverse				
	Max. speed	mph(km/h)	31 (50)			
	Brake	Front/Rear hydraulic dry caliper disc				
Sus- pension	Front suspension	Independent. Double A-Arm (Wishbone type)				
	Rear suspension	Independent. Double A-Arm (Wishbone type)				
Steering type		Rack & Pinion / Electronic Power Steering				



3-4 K9 2400SW(C,F)/K9 2400(D)C/K9 2400F

ITEMS			K9 2400SWC	K9 2400SWF	K9 2400C-EU	K9 2400F-EU	K9 2400DC-AU
Tire	Front wheel	Work /ATV	25 x 10-12				
		Turf	26 x 10.5-12				
	Rear wheel	Work /ATV	25 x 10-12				
		Turf	26 x 10.5-12				
Cargo bed	Dimension (L x W x D)	in.(mm)	43.7 x 58.3 x 11.5 (1,110 x 1,480 x 293)				
	Load capacity	lbs(kg)	1,102 (500)				
Min. turning radius		ft(m)	15.1(4.6) [2WD]				
Gross Weight		lbs(kg)	2,215 (1,050)				
GVWR		lbs(kg)	3,747 (1,700)				
Towing capacity		lbs(kg)	1,300 (590)				
Payload capacity		lbs(kg)	-				
Others	Seat Capacity		3P, 3 Seat Bench		Driver: slide seat Passenger: 2P bench seat		3P, 3 Seat Bench
	Body Color		Orange/Green				
	Speedometer		Standard				
	Front Guard		Standard(with HeadLamp Protect)				
	Heater & Aircon		Standard	Heater Only	Standard	Heater Only	Standard
	USB Port & Power Socket		Standard				



ITEMS		K9 2400SWC	K9 2400SWF	K9 2400C-EU	K9 2400F-EU	K9 2400DC-AU
Others	Engine Brake			Standard		
	Floor Mat			Standard		
	Sunvisor			Standard		
	Room Mirror			Standard		
	Headrest			Standard		
	Parking Brake Buzzer			Standard		
	7 Pin Socket	-	-	Standard		-

3

※ Notes: Some option kits are installed as a standard in a certain country.



OPTION LIST AND FEATURES

ITEM	K9 2400SWC	K9 2400SWF	K9 2400C-EU	K9 2400F-EU	K9 2400DC-AU
Bluetooth Audio	Opt.	Opt.	Opt.	Opt.	Opt.
Swing Drawbar	Opt.	Opt.	Std.	Std.	Opt.
Front Hitch Receiver Kit(EEC)	Opt.	Opt.	Std.	Std.	Opt.
Front Hitch Receiver Kit	Std.	Std.	Opt.	Opt.	Opt.
Winch Bracket	Opt.	Opt.	Opt.	Opt.	Opt.
Hydraulic Dumping Cylinder Kit	Opt.	Opt.	Opt.	Opt.	Opt.
Hydraulic Valve System Kit	Opt.	Opt.	Opt.	Opt.	Opt.
Hydraulic Valve System Kit (floating)	Opt.	Opt.	Opt.	Opt.	Opt.
Remote Hydraulic Utility Valve Kit	Opt.	Opt.	Opt.	Opt.	Opt.
Quick Coupler Kit	Opt.	Opt.	Opt.	Opt.	Opt.
Electronic Dump	Opt.	Opt.	Opt.	Opt.	Std.
Windshield gasspring	Opt.	Opt.	Opt.	Opt.	Opt.
Hand Throttle	Opt.	Opt.	Opt.	Opt.	Opt.
Skid Plate(Steel)	Std.	Std.	Opt.	Opt.	Opt.
Hood Dust Cover	Std.	Std.	Std.	Std.	Opt.
Suspension Dust Guard	Std.	Std.	Std.	Std.	Opt.
Side Mirror	Opt.	Opt.	Std.	Std.	Opt.
License Plate	Opt.	Opt.	Std.	Std.	Opt.



ITEM	K9 2400SWC	K9 2400SWF	K9 2400C-EU	K9 2400F-EU	K9 2400DC-AU
Back Alarm Buzzer	Opt.	Opt.	Opt.	Opt.	Opt.
Working Lamp-Front	Std.	Std.	Std.	Std.	Opt.
Working Lamp-Rear	Opt.	Opt.	Opt.	Opt.	Opt.
Beacon Lamp	Opt.	Opt.	Opt.	Opt.	Opt.
Fog Lamp	Opt.	Opt.	Opt.	Opt.	Opt.
Deck Extension	Opt.	Opt.	Opt.	Opt.	Opt.
Wheel (Work)	Opt.	Opt.	Opt.	Opt.	Std.
Wheel (Mud)	Opt.	Opt.	Opt.	Opt.	Opt.
Wheel (Turf)	Opt.	Opt.	Opt.	Opt.	Opt.
Aluminium Wheel (Work)	Opt.	Opt.	Opt.	Opt.	Opt.
Aluminium Wheel (Mud)	Opt.	Opt.	Opt.	Opt.	Opt.
Sports handle (KIOTI)	Opt.	Opt.	Std.	Std.	Opt.
Sports handle (Daedong)	Opt.	Opt.	Opt.	Opt.	Opt.
Urethane Deck	Std.	Std.	Opt.	Opt.	Opt.
Side Cup Holder	Opt.	Opt.	Opt.	Opt.	Opt.
Sliding Cup Holder	Std.	Std.	-	-	Opt.

※ Notes: Some option kits are not available at the time of printing. The specifications are subject to change without notice.
Some option kits are installed as a standard in a certain country.

NOISE LEVELS AS PERCEIVED BY THE OPERATOR

The following tables give the noise level values, measured from the driver's seat in instantaneous conditions in compliance with standards No.1322/2014(RVCR) AnnexXIII and when driving by in compliance with standard 2015/96(REPPR) AnnexIII.

Item	Vehicles with Cabin		
	(EU) 2015/96(REPPR) AnnexIII (Pass-by)	(EU) 2015/96(REPPR) AnnexIII (Stationary)	(EU)No.1322/2014(RVCR) An- nexXIII (Internal)
Permissible sound level	82 dB(A)	83 dB(A)	82.4 dB(A), method2

※ Note: Data supplied by the manufacturer, approval values pending.

VIBRATION LEVELS OF THE UTV EXPOSITION TO VIBRATIONS

WARNING

- *The vibration level transmitted to the body as a whole depend on different parameters, some of them relating to the machine, others to the terrain and many specific for the operator. The prevailing parameters are the type of terrain or work surface and the ground speed.*
- *Vibrations cause discomfort for the operator and in some cases put his/her health and safety at risk.*
- *Make sure that the UTV is in good condition and that all routine servicing is correctly and regularly carried out.*
- *Check tire pressure and the steering and braking systems.*
- *Check that the operator's seat and adjustment systems are in good condition, then adjust the seat to the operator's weight and size.*

**⊕ IMPORTANT**

- **More information on Whole Body Vibration (WBV) on agricultural UTVs can be found in more specific publications and the relative risks can be taken into account following the laws of the country. In order to correctly estimate statistical values based on your daily work on the UTV, a specific measure instrument is required, such as a three-axis accelerometer applied to the seat**

In accordance to (EU) 1322/2014 Annex14 the following table shows vibration levels measured on seats, in aws.

Operator's Vibration level			
Seat type	Directive of The European Parliament and of the Council	Light-weight operator	Heavy-weight operator
W15050	(EU) 1322/2014 Annex14	1.14 m/s ²	1.05 m/s ²

3

EU TYPE-APPROVAL CERTIFICATE NUMBER AND CO₂ VALUE

EU type-approval number	CO ₂ emission according to Regulation(EU) 2016/1628
e13*2016/1628*2017/656EV2/D*0125*00	1018.5 g/kWh

📖 NOTE

- This CO₂ measurement results from testing over a fixed test cycle under laboratory conditions a(n) (parent) engine representative of the engine type (engine family) and shall not imply or express any guarantee of the performance of a particular engine.



MEMO





CONTROLS AND FEATURES

4

4

EXTERIOR VIEW	4-3	SPEEDOMETER	4-17
HOOD	4-4	HOURLMETER, ODOMETER	4-18
ELECTRIC COOLING FAN MOTOR	4-4	MODE SELECTION BUTTON	4-18
SUSPENSION	4-5	ADJUSTING THE TIME	4-18
HEADLAMP	4-5	FUEL GAUGE	4-19
FRONT HITCH RECEIVER (IF EQUIPPED) ..	4-5	COOLANT TEMPERATURE GAUGE	4-19
DRAWBAR (IF EQUIPPED)	4-6	TURN SIGNAL LAMP	4-20
REAR HITCH RECEIVER	4-6	ENGINE OIL PRESSURE WARNING LAMP	4-20
REFLEX REFLECTOR	4-7	HEAD LIGHT HIGH BEAM LAMP	4-21
SWITCHES	4-8	PARKING BRAKE INDICATOR	4-21
KEY SWITCH	4-8	NEUTRAL INDICATOR	4-22
COMBINATION SWITCH	4-10	SEAT BELT WARNING LAMP (IF EQUIPPED)	4-22
HAZARD LAMP SWITCH	4-12	GLOW PLUG INDICATOR	4-23
WORKING LIGHT	4-13	ENGINE CHECK LAMP	4-23
HEADLAMP SWITCH	4-13	BATTERY CHARGING LAMP	4-23
CARGO BED CONTROL SWITCH (IF EQUIPPED)	4-14	LOWER FUEL LEVEL WARNING INDI- CATOR	4-24
SPARE SWITCH PANEL	4-15	ERROR INDICATOR	4-25
USB PORT & POWER SOCKET	4-15		
INSTRUMENT PANEL	4-17	CONTROLS	4-26



CONTROLS AND FEATURES

SHIFT LEVER.....	4-26	CABIN SYSTEM	4-39
ACCELERATOR PEDAL.....	4-27	INTERIOR DEVICES	4-39
BRAKE PEDAL.....	4-27	ENTRANCE	4-40
PARKING BRAKE LEVER.....	4-29	FRONT WINDOW.....	4-40
DIFFERENTIAL LOCK LEVER (REAR WHEEL).....	4-30	WIPER	4-41
2WD/4WD SHIFT LEVER	4-31	INDOOR LAMP.....	4-42
SEAT.....	4-31	SUN VISOR (IF EQUIPPED).....	4-42
SEAT BELT	4-32	VENT	4-42
HEADREST (IF EQUIPPED).....	4-33	INSIDE REAR VIEW MIRROR (IF EQUIPPED).....	4-43
PASSENGER SEAT	4-33	HEATER AND AIR CONDITIONER	4-44
ROPS	4-34	FAN SPEED CONTROL DIAL.....	4-45
BRUSH GUARD	4-35	AIR CONDITIONER SWITCH (AIR CON- DITIONER).....	4-45
SKID PLATES (STEEL) (IF EQUIPPED)....	4-35	TEMPERATURE CONTROL SWITCH (AIR CONDITIONER).....	4-45
CUP HOLDERS AND STORAGE BOXES..	4-35	TEMPERATURE CONTROL SWITCH (HEATER)	4-47
CARGO BED.....	4-36	CIRCULATION OF INDOOR AIR AND INFLOW OF EXTERNAL AIR.....	4-48
FUEL TANK.....	4-36	TIRE	4-48
HAND THROTTLE LEVER (OPTION).....	4-37	PROPER INFLATION PRESSURE.....	4-50
ENGINE INSPECTION	4-37		
COOLANT, BRAKE FLUID AND ELEC- TRICAL DEVICES.....	4-38		



EXTERIOR VIEW



4

- (1) Hood
- (2) Headlamp
- (3) Turn Signal Lamp
- (4) Door
- (5) Door Handle
- (6) Antenna
- (7) Cabin

- (8) Brush Guard
- (9) Cargo Bed
- (10) Dumping Latch
- (11) Rear Lamp
- (12) Daytime Running Lamp & Side Lamp
- (13) Hitch Receiver (Rear)
- (14) Wiper

- (15) Reflector
- (16) Beacon Lamp
- (17) Rear View Mirror
- (18) Working Lamp (Front)
- (19) Working Lamp (Rear)

U45O458A

HOOD

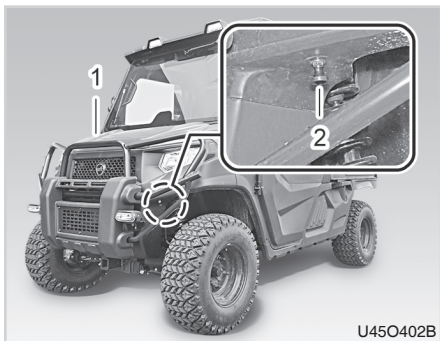

(1) Hood
(A) Hook

The hood lock is a push/pull One Touch ring. Always check that they are firmly engaged.

WARNING

- ***Make sure that the hood is firmly closed and engaged before driving. If not, it may open during driving, resulting in an accident.***

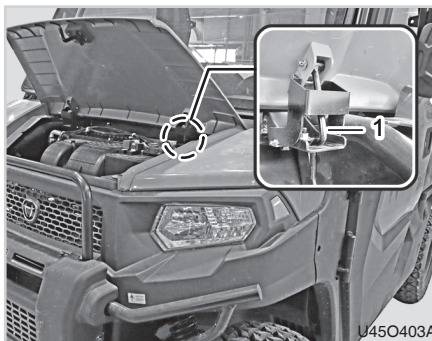

(1) Hood Support

CAUTION

- **Make sure that there is nothing around or between the vehicle and the hood before closing the hood.**

ELECTRIC COOLING FAN MOTOR

The fan motor runs when the coolant temperature raises over 80°C and stops when the coolant temperature drops below 75°C. The 5°C gap between two points is to prevent continual "ON" and "OFF" operation of fan motor. The fan motor can run even when the engine is stopped if the key is in "ON" position and the coolant is still hot.

To prevent engine failure, the fan motor keeps running even if there is any short-circuit or disconnected wire on the temperature signal circuit.

SUSPENSION

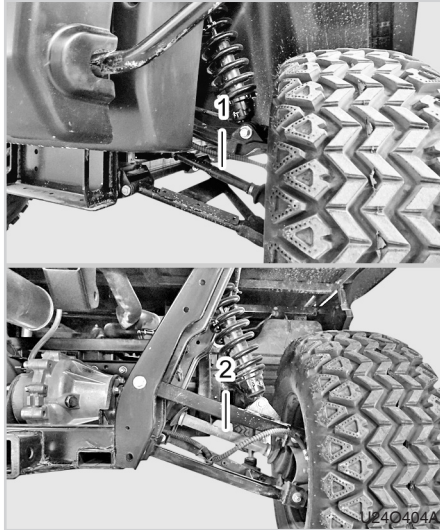

(1) Front Axle (2) Rear Axle

The double A-arm (wishbone) type suspension for front/rear wheel provide smoothest ride off road, empty or at full load.

HEADLAMP



(1) Headlamp (LH) (2) Headlamp (RH)

The headlamps consist of Halogen lamps for high beam and low beam.

⚠ WARNING

- ***Driving with high beam headlamps disturbs the approaching vehicle's visibility for safe driving. Use the high beam headlamps only if necessary.***

FRONT HITCH RECEIVER (IF EQUIPPED)

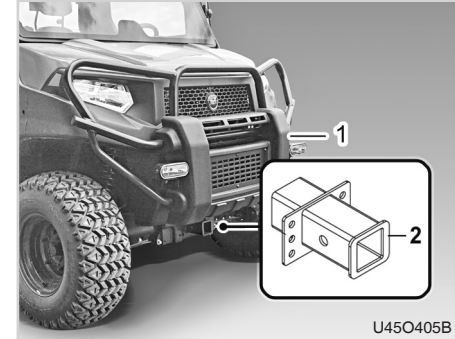

(1) Front bumper (brush guard)
(2) Front hitch receiver

The front hitch receiver is a two-inch square boss type which is installed below the front bumper (brush guard).



DRAWBAR (IF EQUIPPED)

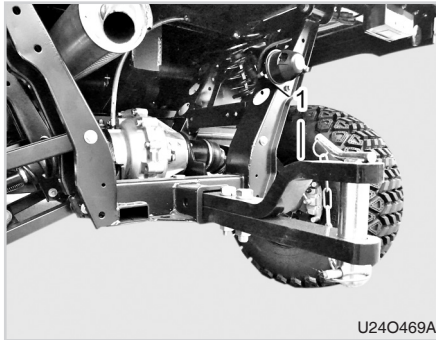

The Drawbar is used to pull an implement, such as a trailer. This UTV is equipped with a drawbar. Make sure to check the Max. towing weight of the trailer and Max. vertical load that can be applied to the drawbar.

(1) Drawbar

Type (according to Appendix 1 to Annex XXXIV to Commission Delegated Regulation (EU) 2015/208)		Tractor drawbar	
Make		DAEDONG, KIOTI	
Manufacturer's type designation		UD21	
(EU) type-approval mark or number		See Annex B	
Maximum horizontal load/D-Value		N/A	
Towable mass (T)		9.34 kN	
Maximum permissible vertical load on the coupling point		200 kg	
Position of coupling point	Height above ground	minimum	272 mm
		maximum	274 mm
	Distance from vertical plane passing through the axis of the rear axle	minimum	538 mm
		maximum	538 mm

REAR HITCH RECEIVER



(1) Rear Hitch Receiver

This vehicle is equipped with the rear hitch receiver as standard.

The rear hitch receiver is a 2-inch square boss type and is used to install a trailer or 3-point hitch implement. Make sure to observe the following precautions in order to prevent injuries and damage to properties.

REFLEX REFLECTOR

⚠ WARNING

- **Never drive this vehicle with a person in the trailer or cargo bed.**
- **Do not apply vertical load for more than 59 Kg (130 lbs) onto the towing bracket.**
- **When towing, do not exceed the driving speed of 16 km/h (10 mph).**
- **Remember that the stopping distance becomes longer while towing a trailer.**
- **When towing a trailer, make sure the gross weight of the trailer, including cargo weight, does not exceed 590 kg (1,300 lbs).**
- **When connecting a trailer, attach it only to the trailer hitch bracket.**
- **Never connect a trailer to any point other than the specified. Otherwise, you can lose control of the vehicle during driving, resulting in a possible accident.**



- (1) Reflex Reflector (LH)
 (2) Reflex Reflector (RH)

Two round reflectors are installed on the rear wheel fender.

⚠ CAUTION

- **Always check that the reflex reflector are clean before driving. Driving with the dirty reflective mirrors, especially in a cloudy weather or at night, can cause an accident.**
- **It is recommended to install the safety lamp kit (if equipped) if driving on a paved road or at night frequently.**
- **In some counties and states, it is illegal to drive UTV in the public road. Be aware the traffic law before driving.**

SWITCHES

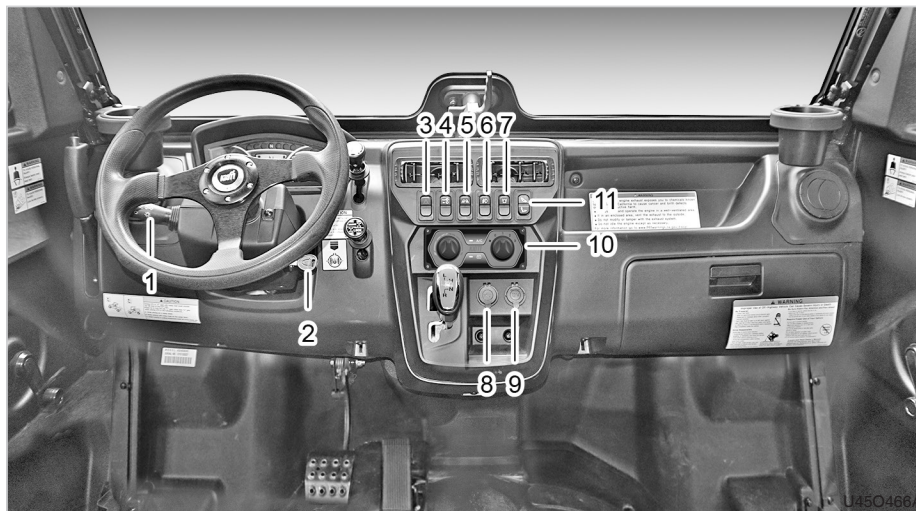

- (1) Combination Switch
- (2) Key Switch
- (3) Hazard Lamp Switch
- (4) Wiper Switch
- (5) Working Lamp Switch
- (6) Headlamp Switch

- (7) Beacon (Option) Switch
- (8) USB Port & Power Socket
- (9) 12V Power Outlet
- (10) Heater/Air Conditioner Control Panel
- (11) Electronic Dump Switch

KEY SWITCH

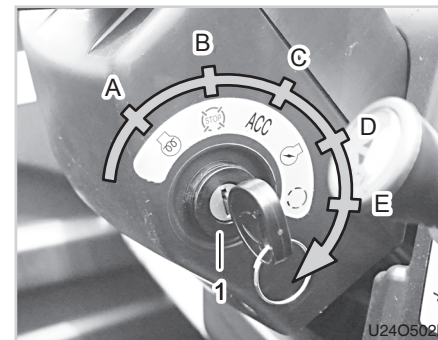

- (1) Key switch
- (A) Preheat
- (B) Stop
- (C) ACC
- (D) ON
- (E) Start

There are five positions for the ignition key switch as follow. The key can be removed from the key switch only if it is in the "OFF" position.

● (A)

The position "A" indicates the "manual preheat" position, which is not used in normal conditions. This position is a self-return type, so the key should be held there while using. This position can be used in

very cold weather to preheat the engine manually for extra period of time. Using this position for more than 30 seconds consecutively can reduce the preheat system's life.

NOTE

- There is no "Manual preheat" function in US models.

(B)

When the key switch is in position "B", the engine and all electrical devices in the vehicle stop except horn, hazard lamps and turn signal.

• ACC (C)

When the key switch is turned to the position "C", only electrical power outlet can be operated.

• (D)

The position "D" indicates the "ON" position. As soon as the key switch is turned to this position, the oil pressure warning lamp and battery charge warning lamp comes on (These become off after the engine is started). The preheat operation is automatically started. The automatic preheat operation is indicated by the glow plug indicator. Make sure to preheat the engine until the glow plug indicator goes off (approx. 9 seconds) in cold weather.

• (E)

The position "E" indicates the "Start". In order to start the engine, the shift lever should be in the neutral position and depress the brake pedal. As soon as the engine is started, release the key then the key switch is returned to the position "D".

NOTE

- The automatic preheating system is not activated and the preheating indicator doesn't come on when the engine temperature is 30°C or higher. In this case, start the engine right away without preheating.

NOTE

- The ignition key is not directional and can be inserted in any direction. Also, be careful not to leave the vehicle unattended as the same key is used for all **KIOTI** vehicles. It can be stolen.

CAUTION

- Stop the engine immediately if the oil pressure warning lamp does not go off after the engine is started. The engine can be seriously damaged.
- If the battery charge warning lamp does not go off after the engine is started, check the electrical systems, such as the alternator, for damage. Continuing to use the engine under this condition can discharge the battery or damage other electrical devices.
- By leaving the vehicle with the key in the ignition switch, an unauthorized person can operate the vehicle and cause a serious accident and even death. Make sure to keep the key with you when leaving the vehicle.

COMBINATION SWITCH

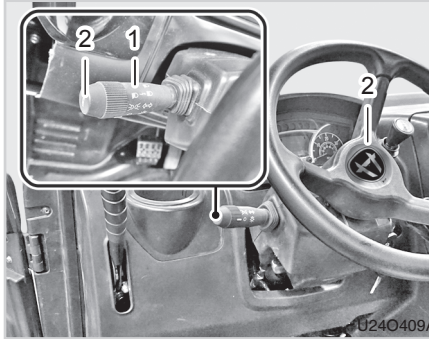



- (1) Turn Signal Lamp Switch & Headlamp Switch
 (2) Horn Switch

The combination switch consists of the head light, turn signal light, and horn switches.

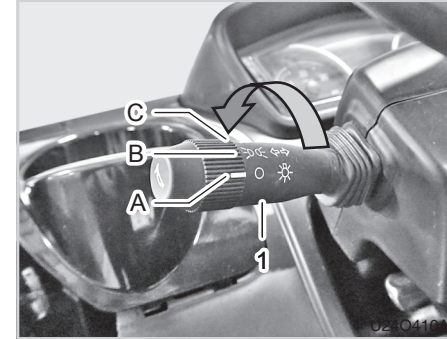
HEAD LAMP SWITCH



- (1) Combination Switch
 (A) OFF : Headlamps Off
 (B)  : Tail lights, Position lamp ON
 (C)  : Head lamp ON

The head lamp switch can be operated while the key switch is in the "ON" position then head lights, tail lights (if equipped) and dash lights come on. Turning on the head lamps for an extended period of time with the engine off can discharge the battery.

⚠ WARNING

- *Driving with high beam headlamps disturbs the approaching vehicle's visibility for safe driving. Use the high beam headlamps only if necessary.*

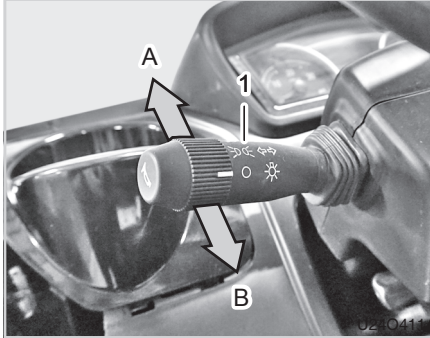
TURN SIGNAL LAMP SWITCH

(1) Combination Switch

(A) Turn signal lamps On (R)

(B) Turn signal lamps On (L)

Pulling the lever up blinks the right turn signal lamp while pushing the lever down blinks the left turn signal lamp.

The turn signal lamp switch is to operate the turn signal lamps, which is included in the "Safety lamp kit" as an option. Check if the safety lamp kit is installed before using this switch.

📖 NOTE

- The turn signal lamp lever is not the self-return type. Therefore, make sure to return the lever manually after turning the vehicle.
- The turn signal lamps and flasher can be operated even with the key switch in the "OFF" position. Leaving the turn signal lamps flashing with the key switch in the "OFF" position can discharge the battery.
- It is recommended to install the "safety lamp kit" (If equipped) if driving on the public road or at night frequently.



HORN SWITCH

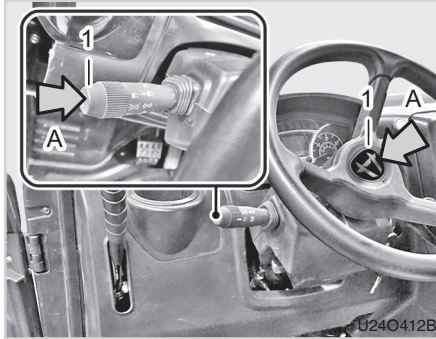

(1) Horn Switch
(A) Press

The horn switch can be operated without the key in the key switch. Pressing this switch sounds the horn.

HAZARD LAMP SWITCH

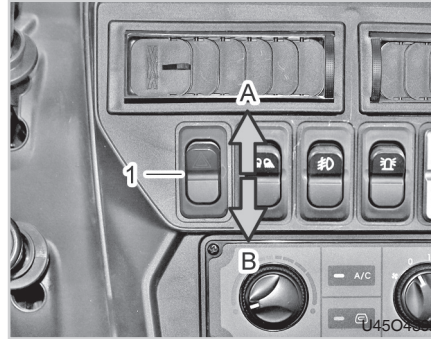

(1) Hazard lamp switch
(A) ON (B) OFF

This switch can be used to warn other vehicles when malfunction occurs in the vehicle while driving on a public road. Pressing this switch up blinks the hazard lamp and returning it turns off the lamp. The turn signal lights cannot be operated while this switch is pressed up to operate the hazard lamps.

⚠ CAUTION

- The hazard lamp can be operated without the key inserted.
- If the hazard lamps are turned on for an extended period of time while the engine is stopped, the battery can be discharged. Therefore, use them only in emergency.

WORKING LIGHT

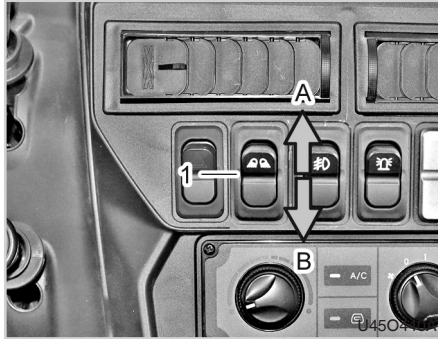

(1) Working Light Switch
(A) ON (B) OFF

The working lights are installed to the front and rear sections of the roof, and their operating button is installed to the right panel in the cabin.

To turn on, position the switch marked (front) to "ON" the position.

The key switch should be positioned to the "ON" position at this moment.

⚠ WARNING

- **Do not drive the UTV on a road with the work lights ON at night.**
- **The approaching or following vehicle's visibility can be disturbed, which is very dangerous for both drivers. In this case, use the hazard lamps.**

HEADLAMP SWITCH

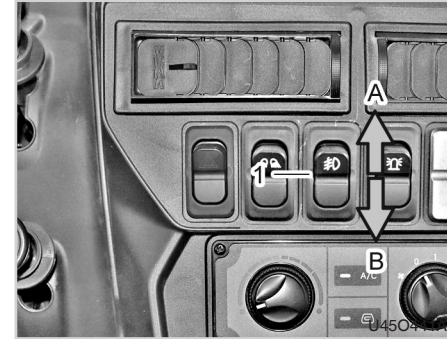

(1) Headlamp Switch
(A) ON (B) OFF

The headlamp switch can be operated only while the key switch is turned to the "ON" position.

CARGO BED CONTROL SWITCH (IF EQUIPPED)

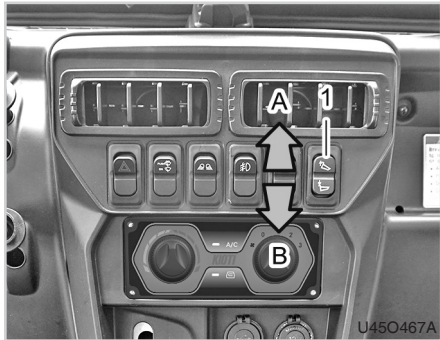

(1) Cargo Bed Control Switch
 (A) Up (B) Down

With the engine running, the cargo bed can be raised or lowered using the switch. Never operate the switch while driving.

⚠ CAUTION

- When the key is turned on, the cargo bed can be raised and lowered. However, during continuous operation, excessive current enters the motor and causes malfunction, so be sure to operate it with the engine on.
- Do not carry more than the maximum load specified below in the loading box.

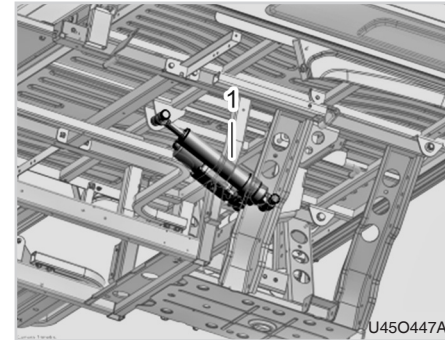

(1) Lift Cylinder

⚠ WARNING

- **Never let anyone ride on the cargo bed during driving. He/she can fall off the bed and be seriously injured.**
- **It is dangerous to drive with the cargo bed raised. Make sure to lower the cargo bed to its original position and engage the latch before driving.**

⚠ WARNING

- *When raising or lowering the cargo bed, be careful not to let any part of your body, such as a hand or foot, stay between the cargo bed and cab frame.*
- *Repeated operation of the electronic dump with the maximum load may cause the motor to stop working temporarily (when the temperature rises above 85 °C) due to an increase in the motor temperature. As this is a safety device to prevent motor overload, it will restart when the motor temperature drops below a certain temperature (about 55 °C).*

SPARE SWITCH PANEL



(1) Spare Switch Panel

The spare switch panel is prepared in case that the owner wants to install the switches for the optional working lamps, wiper and other implements. If no switch is installed to this panel, a plastic plug is installed instead.

USB PORT & POWER SOCKET

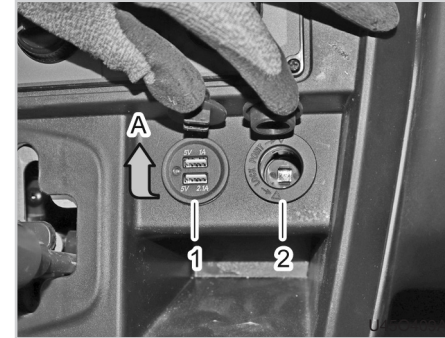

(1) USB Port
(A) Open

(2) 12V Power Outlet

This USB Port & Power Socket operates with the key in the "ACC" or "ON" position.

Using the power outlet for an extended period of time with the engine off or connecting an electric device with its capacity over the limit into the power outlet can discharge the battery.



4-16 K9 2400SW(C,F)/K9 2400(D)C/K9 2400F

 **WARNING**

- *Do not wear a headphone to listen to the radio or music during driving.*
- *Use only D.C. electric devices with its capacity of 12V 10A or less.*
- *Never use an electric heater. It can cause a fire.*

INSTRUMENT PANEL

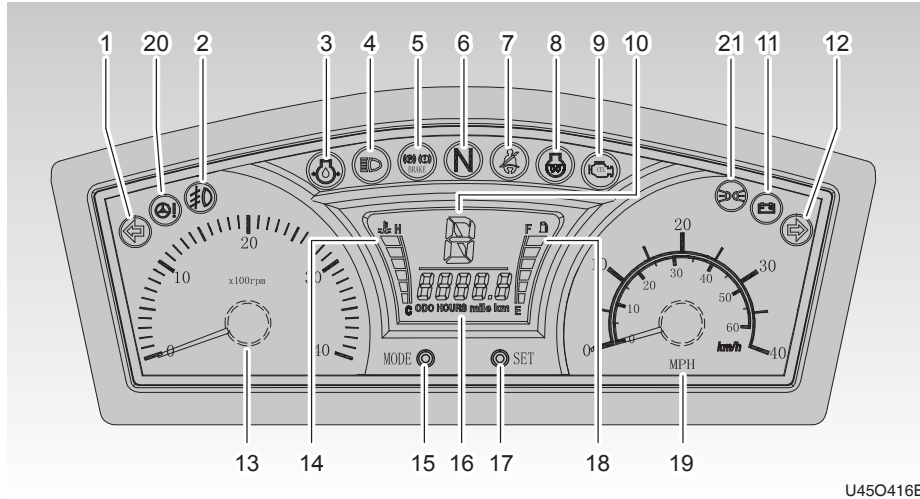

- | | |
|--------------------------------------|---------------------------------|
| (1) Turn Signal Indicator (Lh) | (12) Turn Signal Indicator (Rh) |
| (2) Fog Lamp | (13) Tachometer (Rpm) |
| (3) Engine Oil Pressure Warning Lamp | (14) Coolant Temperature Gauge |
| (4) Headlamp High Beam Lamp | (15) Mode Switch |
| (5) Parking Brake Indicator | (16) Hour Meter |
| (6) Neutral Indicator | (17) Set Switch |
| (7) Seat Belt Warning Lamp | (18) Fuel Gauge |
| (8) Glow Plug Indicator | (19) Speedometer |
| (9) Engine Check Lamp | (20) EPS Error Indicator |
| (10) Gear Selection Indicator | (21) Tail Lamp / Sidelight |
| (11) Battery Charging Lamp | |

SPEEDOMETER

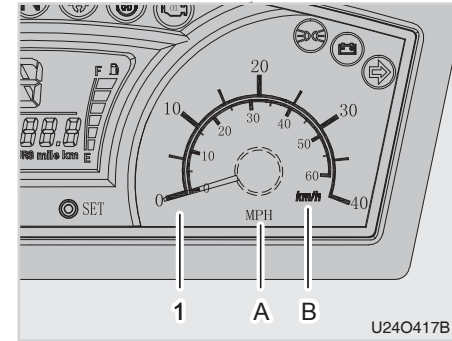

- (1) Speedometer
 (A) MPH (B) Km/h

The 12V voltage supply device activates in “ON” or “ACC” mode.

The battery may discharge if used for extended periods of time with the engine turned off or an electrical product which exceeds the capacity is used.

HOURLMETER, ODOMETER

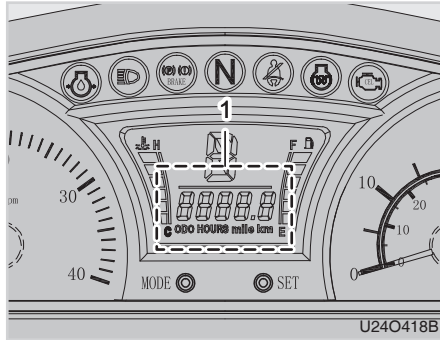

(1) Hourmeter, Odometer

The hourmeter/Odometer displays the total time of use and mileage.

MODE SELECTION BUTTON

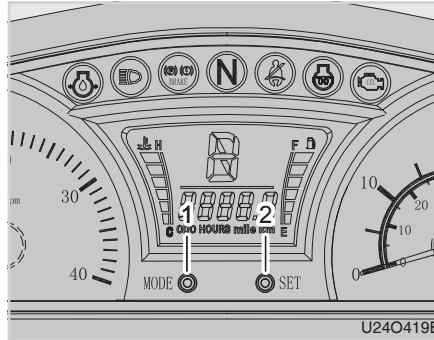

(1) Mode selection button (2) Set button

Mode selection button	Display	Note
Push once	Odometer	Total mileage
Push twice	Hourmeter	Total time used
Push three times	Clock	Current Time

※ Press the SET button to switch the speed unit to km or mile.

ADJUSTING THE TIME

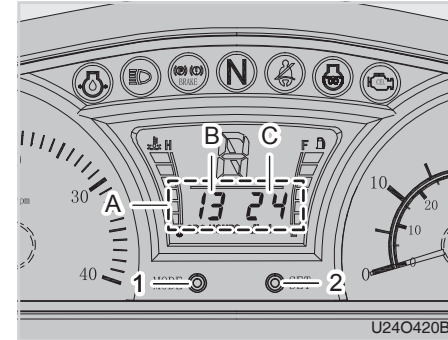

(1) Mode selection button (2) Set button
 (A) Hour meter (B) Hour display
 (C) Minute display

When the Hour meter (A) is shown on the display screen:

- If you hold down the mode selection button for long enough, the hour display (B) flickers and can be adjusted, allowing the time to be adjusted with the Set button.
- If you hold down the mode selection button briefly after completing the adjustment of the time, the minute display (C) flickers and can be adjusted. The display is automatically set if a certain amount of time passes after finishing the adjustment with the Set button.

FUEL GAUGE

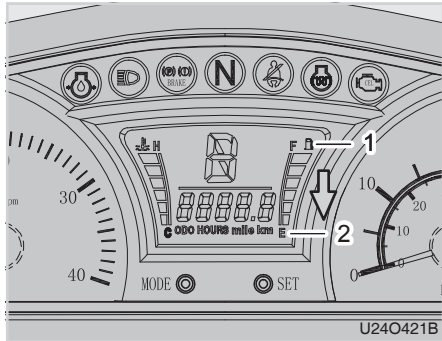

- (1) Fuel level indicator
(2) Fuel level warning lamp

"E": Empty "F": Full

This indicates the remaining fuel level after the key switch is turned to the "ON" position.

F : Fuel is completely filled.

E : Replenish the fuel tank.

If driving is continued with the needle below the position "E", the warning lamp of out of fuel() turns on. In case of running out of fuel, it may be hard to restart the engine even after replenish the fuel tank with fuel.

This is due to air entered into the fuel supply system. In this case, the system should be bled. (For details, refer to page 7-19 "Bleeding fuel system" in the chapter "Maintenance".)

NOTE

- Make sure to use only genuine fuel as the engine can be damaged if unqualified fuel is used.
- Use fuel for winter season in cold weather to start the engine easier.

COOLANT TEMPERATURE GAUGE

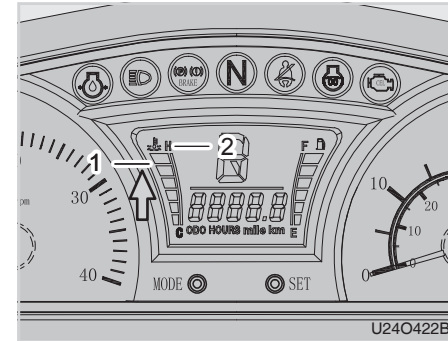

- (1) Coolant Temperature Gauge
(2) High temperature warning lamp

"C": Cold "H": Hot

This gauge indicates the coolant temperature after the key switch is turned to the "ON" position.

C : Coolant is cold.

H : Coolant is hot.

The range marked "2" in the figure indicates the normal engine temperature. (Normal driving range)

If the needle is in the "H" zone during driving, it indicates the engine is overheated.

Stop the vehicle or operation for a while without stopping the engine until the engine is cooled down. If the engine temperature does not drop, open the hood and check if the radiator fan is operating. If the fan is not operating, stop the engine and have your vehicle checked by your dealer.

CAUTION

- **Make sure to control the work load so that the pointer is not in the red zone.**
- **If the pointer stays in the red zone, do not stop the engine immediately. Instead, reduce the work load to cool down the engine before stopping the engine.**
- **Make sure to keep the front grill clean so that air is sucked through it freely for fast cooling.**
- **Never open the radiator cap when it is hot. You can get burnt badly.**

TURN SIGNAL LAMP

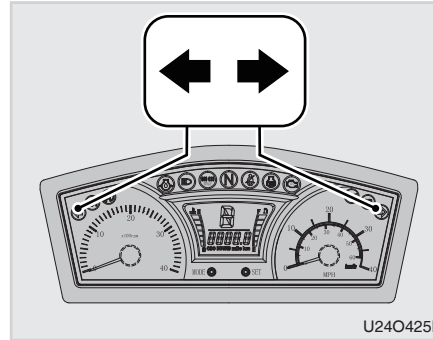

U24O425B

Operating the turn signal lamp switch up and down turns on the corresponding lamp in green.

They operate when the "safety lamp kit (If equipped)" is installed.

ENGINE OIL PRESSURE WARNING LAMP

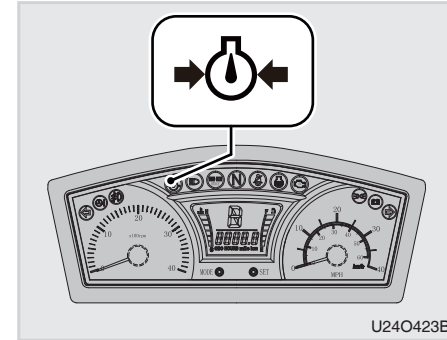

U24O423B

This lamp comes on when the engine oil pressure or oil level is low.

This lamp comes on when initially turning the key switch to the "ON" position. It goes off as soon as the engine is started. If this lamp comes on while driving, stop the engine immediately and check the engine oil level.

If this lamp comes on even with the

specified engine oil level, have your vehicle checked by your local **KIOTI** dealer or workshop immediately.

CAUTION

- If the oil level is below the specified range, the engine can seize.
- The engine can be severely damaged if driving or operating the vehicle with the engine oil warning lamp ON.

HEAD LIGHT HIGH BEAM LAMP

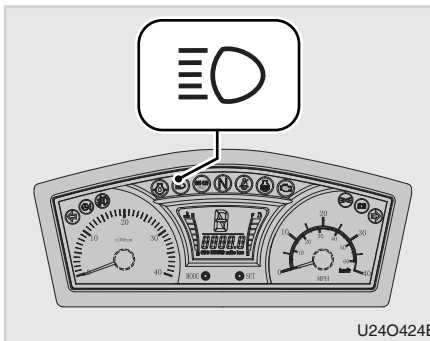

This lamp comes on in blue when the high beam head light is switched on.

Driving with high beam head light disturbs an approaching vehicle's visibility. For safe driving, use the high beam head light only if necessary.

PARKING BRAKE INDICATOR

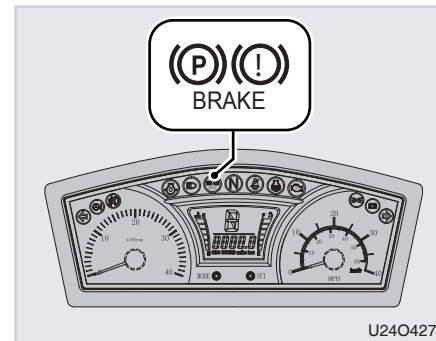

This lamp comes on in red when the parking brake is engaged.

CAUTION

- If this indicator is ON even with the parking brake released, check the brake oil level (for EU model) or have the vehicle checked by your local **KIOTI** dealer or workshop immediately.



NOTE

For EU model:

- If the level of brake oil is low this lamp will be flashed.

NOTE

- If the driver stand up from the driver's seat with parking brake is not engaged, the parking brake lamp blinks and the buzzer sounds (for 10sec).
- When the vehicle moves with the parking brake is engaged, the parking brake lamp blinks and the buzzer sounds.

NEUTRAL INDICATOR

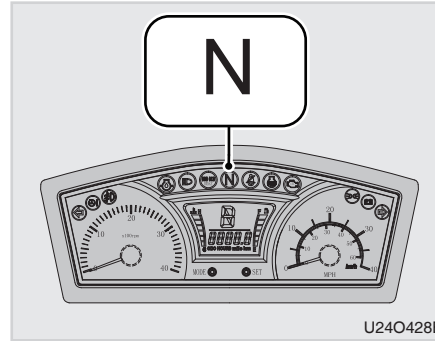

If the shift lever is in neutral position, this lamp turns in green.
Engine can be started only when this lamp is ON.

SEAT BELT WARNING LAMP (IF EQUIPPED)

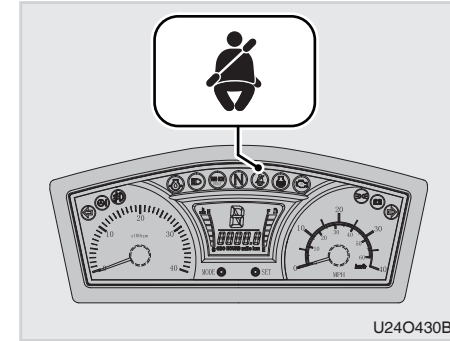

Please put on your seat belt before driving. Otherwise the seat belt warning lamp turns on.
In the case of three-seaters, the lamp remains on unless everyone is wearing their seat belt.

GLOW PLUG INDICATOR

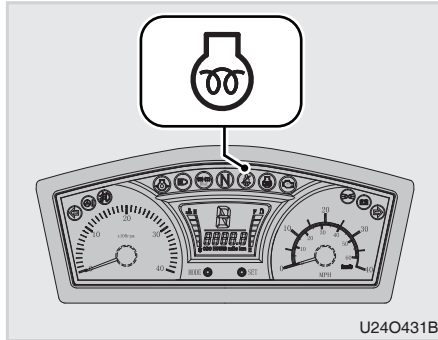

This indicates the operating condition of the preheat system. When the key switch is turned to the "ON" position, this indicator comes on for approx. 9 seconds. It is recommended to start the engine as soon as this indicator goes off for best starting performance. This indicator may not turn on if the engine is warm. In this case, the engine can be started without the preheat operation.

ENGINE CHECK LAMP

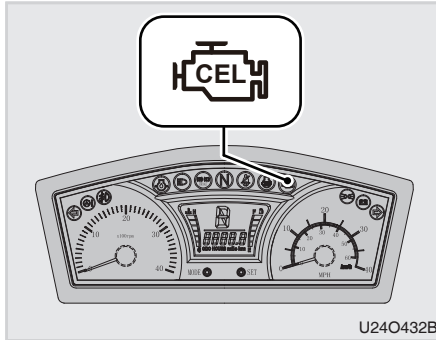

This comes on when any major electric device or engine fuel system is malfunctioning.

BATTERY CHARGING LAMP

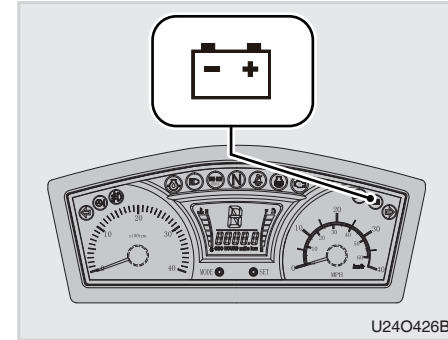

This lamp is turned on when the key switch is turned on before starting the engine but turned Off after starting the engine.

CAUTION

- If this warning lamp comes on while driving, the charging system, such as the alternator, is malfunctioning. Therefore, turn off all electrical devices and have the vehicle checked by your local KIOTI Dealer or workshop as soon as possible.

LOWER FUEL LEVEL WARNING INDICATOR

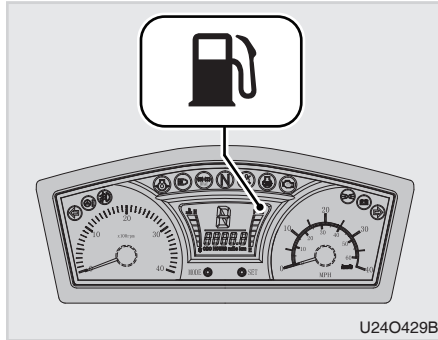

This lamp comes on when the fuel tank is approaching empty. When it comes on, you should add fuel as soon as possible. Driving with the this lamp on or with the fuel level below "E" can cause the engine to mis-fire and damage the engine parts.

If the air enters into the fuel system refer to maintenance chapter page 7-19 for "Bleeding fuel line".

ERROR INDICATOR

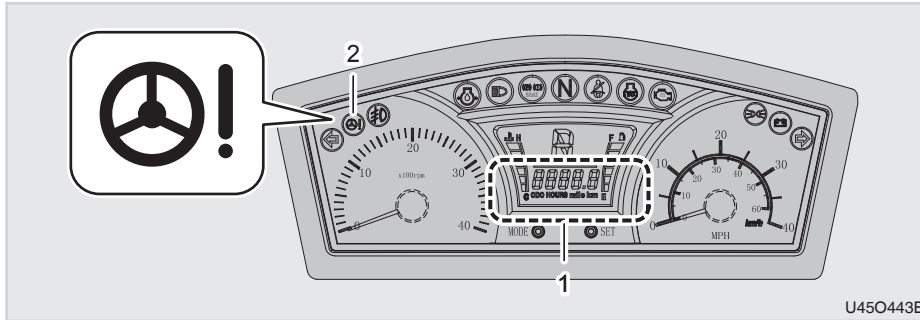

U45O443B

(1) Display

ERROR CODE DISPLAY PRIORITY

- 0X12 > 0X13 > 0X14 > 0X15
- When multiple errors occur, the error code is displayed according to the code priority. The code of priority 1 is displayed, and the next error code is displayed when resolving the priority error.

WARNING

- **Contact to local KIOTI dealer.**

4

You can see the Error code below on the LCD window for Hour meter. When You found these on the LCD, please contact with KIOTI dealer.

NO.	DISPLAY	DESCRIPTION	
1	0X12	Togg sensor error	3 0.5 1.5 0.5 0.5 0.5
2	0X13	Motor error	3 0.5 1.5 0.5 0.5 0.5 0.5
3	0X14	Power supply error	3 0.5 1.5 0.5 0.5 0.5 0.5 0.5
4	0X15	Controller and communication failure	3 0.5 1.5 0.5 0.5 0.5 0.5 0.5 0.5

CONTROLS



- (1) Steering Wheel
- (2) Differential Lock Lever
- (3) Shift Lever

- (4) 2WD/4WD Shift Lever
- (5) Brake Pedal
- (6) Accelerator Pedal

SHIFT LEVER



- (1) Shift lever
- H: High speed L: Low speed
- N: Neutral R: Reverse

The shift lever has four positions; "H" (High speed), "L" (Low speed), "N" (Neutral) and "R" (Reverse).

This vehicle is equipped with the in-line type shift lever system for convenient control. Also, there is a stopper between the "H" and "N" positions to ensure safe shift between the forward and reverse operation.

⊕ IMPORTANT

- This vehicle is equipped with a CVT (Continuous Variable Transmission).
- Make sure to stop the vehicle before moving the shift lever into the "H", "L" or "R" position. Shifting during driving can damage parts in the gearbox.
- Use the engine braking function of the CVT as an auxiliary means of braking.
- Shift the lever into the "L" (Low speed) position when driving on a hill or a bumpy area so that the vehicle can utilize more power and enhance durability of the CVT belt and pulley.

ACCELERATOR PEDAL

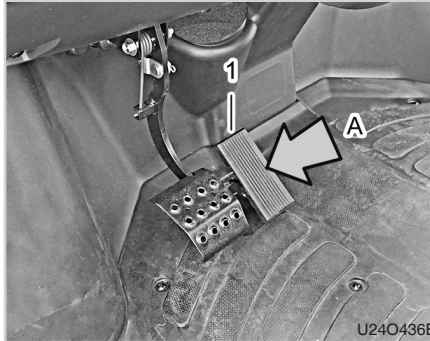

(1) Accelerator Pedal
(A) Depress

The accelerator pedal is located on the right of the brake pedal. Make sure not to depress the brake pedal instead of the accelerator pedal and vice versa by mistake.

BRAKE PEDAL

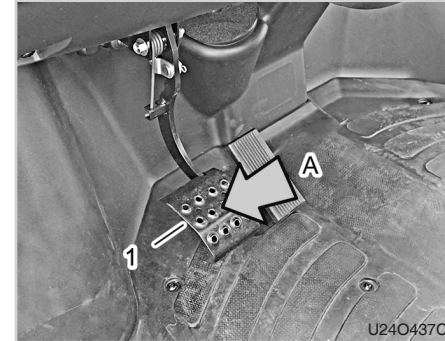

(1) Brake Pedal
(A) Depress

The brake pedal is located on the left of the accelerator pedal. Depress the brake pedal slowly to stop the vehicle or reduce the driving speed.

Make sure to depress the brake pedal before entering a downhill condition to prevent the vehicle from rolling down.



⊕ IMPORTANT

- **Depress the brake pedal lightly for several times to dry the brake disc after driving over water or driving out of a muddy pit so that the brake is properly operated when it is needed.**

When driving on long downhill roads, change to a lower gear and use the foot brake simultaneously according to the circumstances. Overusing the foot brake causes "fade" or "vapor lock" phenomenon due to overheating of the brake system, which reduces braking performance.

FADE

Fade refers to a decrease in frictional force and reduced brake effectiveness caused by overusing the brakes on long downhill roads and thereby causing the brake's friction surface temperature to increase.

VAPOR LOCK

Vapor lock refers to the phenomenon in which overusing the brakes on long downhill roads causes bubbles to form in the brake fluid within the brake's wheel cylinder or brake pipe, thereby preventing a sufficient amount of hydraulic pressure from being transferred even when the brake pedal is depressed and ultimately leading to brake failure.

⚠ CAUTION

- **Depressing the brake pedal to the full position in 2 to 3 steps guarantees more stable braking performance while notifying any vehicles following behind that you are going to brake, thereby preventing collisions.**
- **Only apply as much force to the brake pedal as is needed to stop the vehicle.**



PARKING BRAKE LEVER

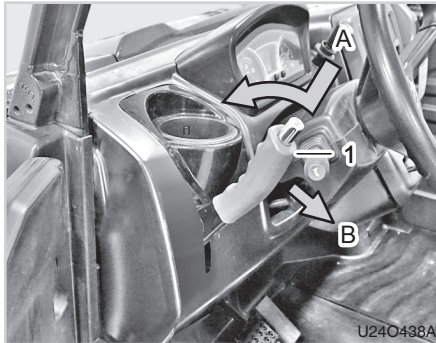

(1) Parking Brake

(A) To deactivate it, hold the button down while pushing upwards

(B) To fix it in place, pull downwards

The parking brake lever is similar to the one installed to cars. Make sure that the parking brake is released before driving.

WARNING

To avoid possible injury, death or loss of property from a machine runaway:

- *With the engine off, the vehicle may move unexpectedly regardless of the gear shift position.*
- *Before leaving the vehicle certainly apply the parking brake to prevent machine runaway.*

WARNING

- *An unauthorized person or child can move or operate the vehicle. Therefore, make sure to apply the parking brake and carry the key with you when leaving the vehicle.*
- *This vehicle is equipped with the CVT (Continuous Variable Transmission). Therefore, the vehicle may roll down a slope if the parking brake is not engaged even though the shift lever is in the "H", "L" or "R" position. Make sure to apply the parking brake before leaving your vehicle.*

DIFFERENTIAL LOCK LEVER (REAR WHEEL)

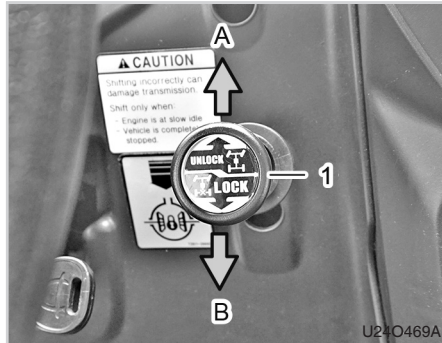

(1) Differential Lock Lever
(A) Upper Position: Unlock
(B) Lower Position: Lock

On hard firm ground, the differential system should be unlocked to secure safe turning.

When the wheel on one side is on a slippery surface, such as mud or icy road, the wheels on a slippery surface lose traction and rotate fast while the wheel on a normal surface do not rotate, resulting in the vehicle stuck into its position. In order to prevent this situation, this vehicle is equipped with the differential lock system.

[DIFFERENTIAL LOCK SYSTEM]

The differential lock system is to connect the wheel on the left and right mechanically to rotate them at the same speed regardless of friction applied to them even on a slippery or bumpy road for better traction.

CAUTION

- The differential lock lever should be placed back into the “Unlock” position after placing it into the “Lock” position to drive on a bumpy road or to free the vehicle. If the diff. lock is often used unnecessarily or used on a normal road continuously, gears related to the axles can be damaged or worn.

CAUTION

- Make sure to set the steering wheel in the straight ahead position and drive at a low speed while the differential lock lever is in the “Lock” position. Otherwise, you can lose control of the vehicle or damage the differential system, resulting in an accident.
- Make sure to move the differential lock lever to the “unlock” position while the vehicle is stationary. Moving the lever during driving can affect the life of the differential system.

LSD DIFFERENTIAL LOCK (FRONT WHEEL)

The LSD (Limited Slip Device) is installed on the front axle.

LSD diff. lock system automatically adjust the wheel rotation speed difference on both wheel so that helps to distribute the traction force evenly to both wheels even if the road friction condition on both wheel is extremely different. It acts like a automatic diff. lock system.

2WD/4WD SHIFT LEVER

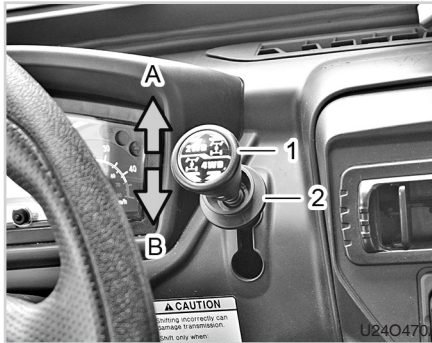

(1) 2WD/4WD Shift Lever (2) Lock
(A) 2WD Position (B) 4WD Position

The 2WD/4WD shift lever is equipped with a lock which should be pulled up by a finger in order to operate the lever. (So does diff. lock lever)

The 4WD should be used only on a slippery surface, bumpy road or steep slope that is lack of friction. The 2WD should be used in a normal condition.

The gears in the vehicle can be stressed and steer ability can be deteriorated if using the 4WD unnecessarily.

SEAT

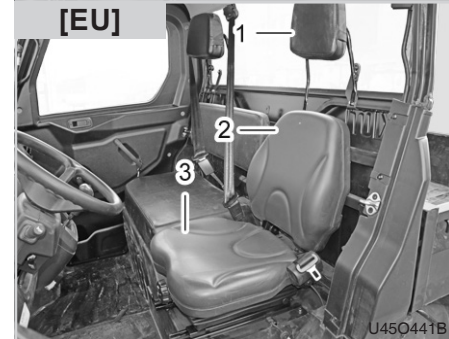
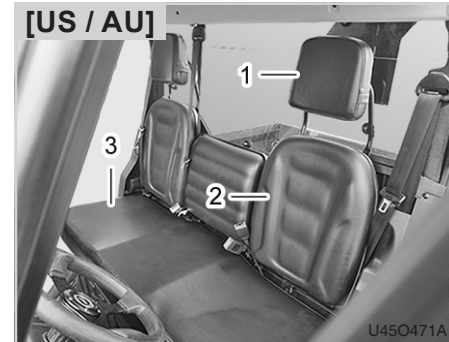

(1) Headrest (2) Seat back
(3) Seat cushion



SEAT BELT

The driver's seat and passenger seat are a bucket and bench-type seat, respectively. In order to see the engine compartment, you must first remove the seat cushion on the passenger seat, then remove the top cover of the engine compartment.

WARNING

- ***Never Leave the driver's seat while the engine running.***



(1) Seat Belt

The seat belts for a driver, passenger and center seat are retractable 3-point lap belts.

1. Make sure the seat belt is not twisted and insert the latch plate into the buckle until a clicking sound is heard.
2. Press the red button to un-buckle.

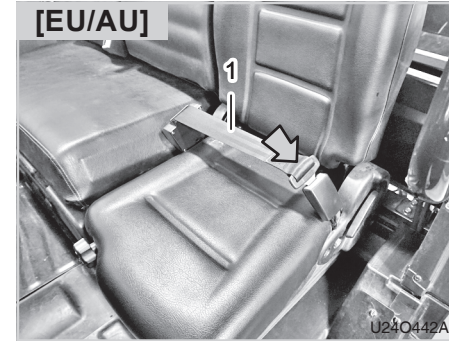

(1) Seat Belt

The seat belts for a driver and passenger are retractable 2-point lap belts while the center seat belt is a non-retractable 2-point lap belt.

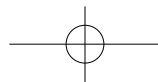

**⚠ WARNING**

- **As the safety belt can reduce or prevent injuries in an accident, make sure to wear the seat belt during driving. Also, be sure the seat belt is not twisted as the seat belt may not protect an occupant properly, leading to an accident.**
- **Fasten the seat belt firmly when seated in the vehicle.**
- **The seat belt should go around your pelvis or as low as possible, not your waist or abdomen. Otherwise, the seat belt cannot protect you properly.**
- **Children under age 5 should never be on this vehicle.**

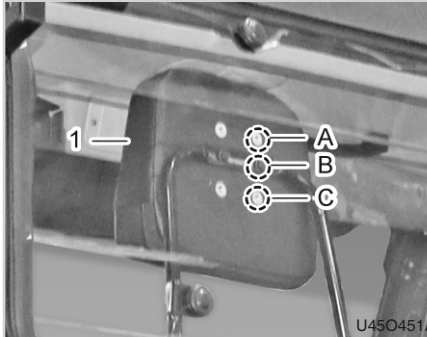
HEADREST (IF EQUIPPED)

(1) Adjustable Headrest (A) Upper
(B) Middle (C) Lower

The headrest can be installed on the driver and passenger positions on the rear frame.

Its height of headrest can be adjustable with three steps.

PASSENGER SEAT

(1) Bench Type Seat

Bench type is different according to each specification.

The seat cushion can be separated.
 Removing the seat cushion can access to the engine compartment.

ROPS

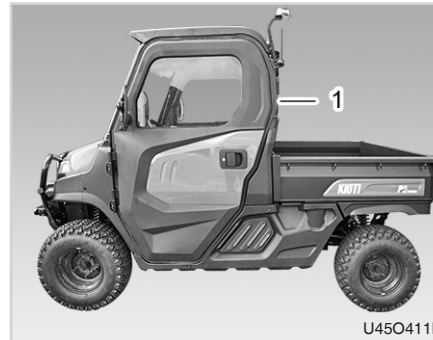

U45O411B

(1) ROPS

The **ROPS** (Roll Over Protective Structure) is a unit made of robust metal tubes in order to protect the driver and occupants in an accident. The **ROPS** installed in **KIOTI**'s vehicles complies with various regulations. (EEC, SAE, ANSI)

⚠ WARNING

- **Make sure to fasten the seat belt during driving. The ROPS cannot protect you if not wearing the seat belt.**

⚠ WARNING

- **The ROPS is to protect you in a rollover accident, not to protect you from falling objects. Never drive in a dangerous or construction area that may have falling objects. Occupants can be seriously injured.**

📖 NOTE

- **ROPS:** Roll Over Protective Structure
- **FOPS:** Falling Object Protective Structure (installed mainly to construction machinery)



UUVO143A

BRUSH GUARD



(1) Brush Guard

The brush guard is made of strong metal tubes to protect the headlamps and radiator. It has a winch installation hole so that the WARN® winch can be installed to the vehicle.

SKID PLATES (STEEL) (IF EQUIPPED)

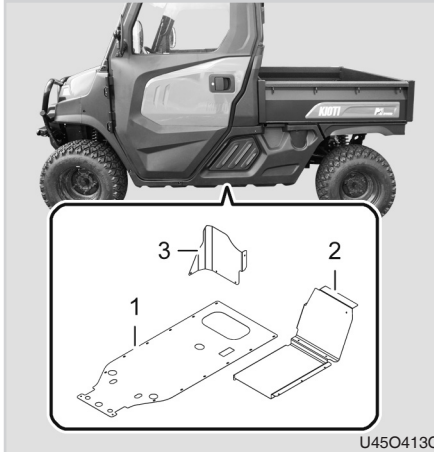

(1) Skid Plate 1 (2) Skid Plate 2
(3) Skid Plate 3

The skid plates can be equipped to protect the driving shaft, gearbox, and battery engine components underside the vehicle.

CUP HOLDERS AND STORAGE BOXES

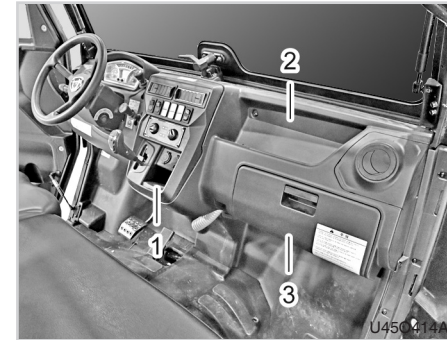

(1) Glovebox (Center)
(2) Glovebox (Driver Side)
(3) Glovebox (Passenger Side)

On the dashboard, there are 2 open storage boxes and 1 glove box with a lid.



CARGO BED

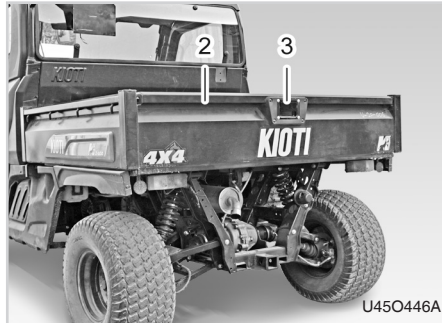

U45O446A



U45O416A

(1) Wire Rope (2) Door (3) Latch Handle
(A) Close (B) Open

To open the back door of the cargo bed, rotate and pull the handles on the both sides simultaneously. Also, make sure the latch handles are securely locked after closing the back door.

FUEL TANK

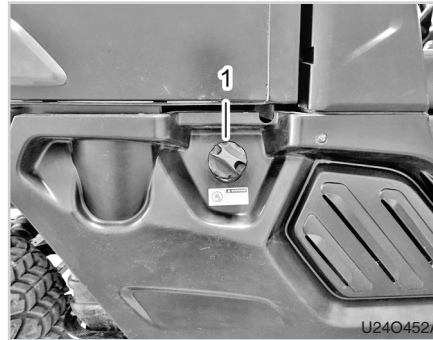

U24O452A

(1) Fuel Tank cap

The fuel tank is installed under the right side of the cargo bed and its capacity is 9.8 gallons (37 liters). Since this vehicle is equipped with the diesel engine make sure to fill the fuel tank with clean diesel fuel for optimal performance.

Make sure to keep the following safety precautions when fueling.

1. Make sure that the fuel to be filled into the tank is diesel fuel.

2. Avoid using electrical devices, such as a cellular phone, during fueling.
3. The fuel is highly flammable and even explosive in certain conditions. Make sure to stop the engine and remove the key before fueling.
4. Never smoke while fueling. Add fuel in a well-ventilated area and keep away from spark and flame.
5. Do not fill the tank with fuel up to the top. The fuel can expand by heat, resulting in leakage through the bleeding hole in the fuel tank filler cap.
6. Make sure to close the tank filler cap firmly after fueling. If fuel overflows, wipe it with a rag immediately.



HAND THROTTLE LEVER (OPTION)

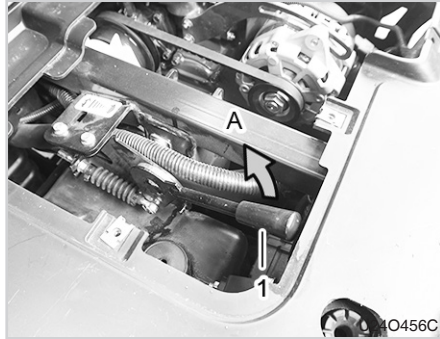

(1) Hand Throttle Lever
(A) PULLING

Use this hand throttle lever to raise up the engine RPM while using remote hydraulic.

Be sure to return the hand throttle lever to its lowest position after using.

WARNING

- ***Make sure that the hand throttle lever is in its lowest position before driving the vehicle. Otherwise, the vehicle may take off abruptly and cause a fatal accident.***

ENGINE INSPECTION

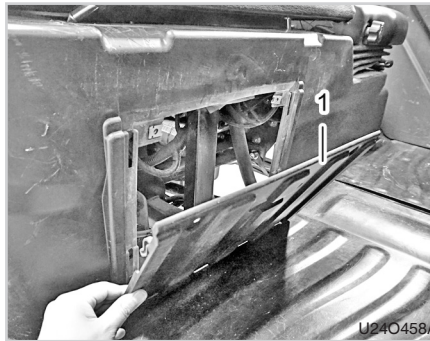
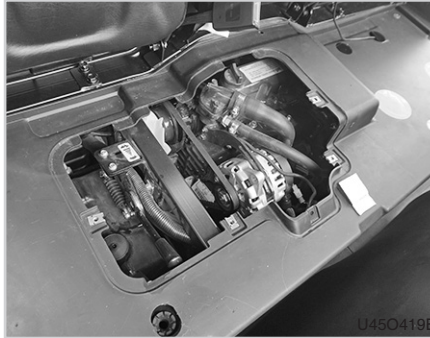

(1) Inspection Shield

It is possible to inspect the engine for most items by removing the seat cushion and raising the cargo bed. For engine oil level check, just remove the inspection shield on the lower section of the seat.

COOLANT, BRAKE FLUID AND ELECTRICAL DEVICES

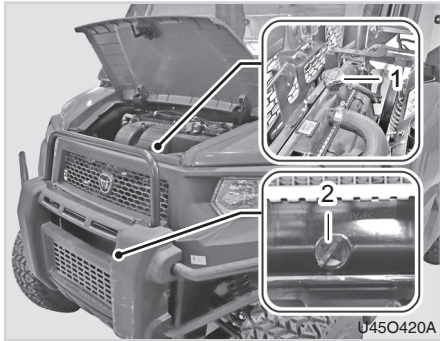

(1) Radiator Cap (2) Drain Plug

The coolant, radiator cooling fan and brake fluid can be checked by opening the hood.

Also, various relays and controls for electrical devices can be checked in this location.

The coolant reservoir tank can be inspected without opening hood, right behind the right front wheel.



CABIN SYSTEM INTERIOR DEVICES

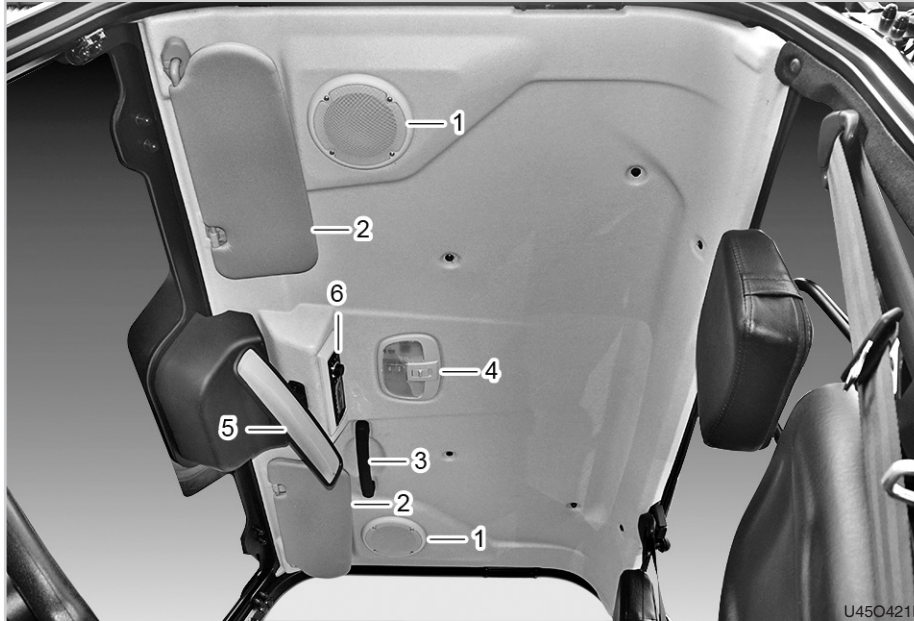

(1) Speaker
(2) Sun Visor
(3) Handle

(4) Room Lamp
(5) Room Mirror
(6) Bluetooth Player/Radio



(1) Wiper
(2) Rear View Mirror
(3) Beacon Lamp
(4) Door Handle
(5) Working Lamp

1. The cabin is designed optimally for the driver's comfort and convenience.
2. This UTV has wide windows as well as outside rearview mirrors on both sides to provide a clear and wide rear view.
3. The cabin can be kept comfortable and pleasant by operating the air conditioner and heater.



4. The cabin structure is safe as it is verified by the ROPS (Roll Over Protection Structure) test. However, make sure to fasten the seat belt for the best protection.

ENTRANCE



(1) Door Handle

Pull the handle forward to open the door.

The door can be locked through the lock on the outside of the door with the ignition key.

FRONT WINDOW

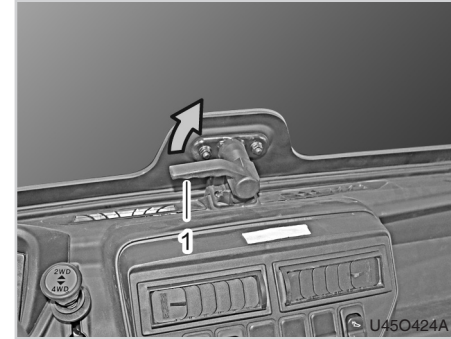

(1) Handle of Front Window
(2) Locking Device

Turn the locking device of the front window to the right and push up the front window slightly to open naturally by the left and right cylinders. When closing, pull the handle and hang it on the latch.

+ IMPORTANT

- In an emergency, please escape through the front window.



WIPER

⚠ WARNING

- *The front window may not be opened due to an implement. Make sure there is enough space to open the window to prevent damage and breakage by an implement.*
- *Never drive the UTV with the door open. An accident can occur.*



- (1) Wiper
(2) Wiper Operating Switch

1. To turn on, position the switch marked (wiper) to the "ON" position.

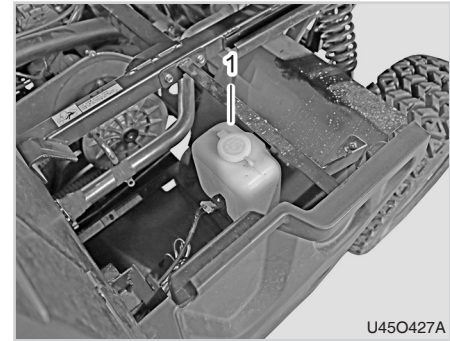

(1) Washer Fluid Tank

2. The washer fluid is sprayed through the nozzle of the wiper by pressing the switch again with the key switch in the "ACC" or "ON" position.
3. The washer fluid for the windshield is installed on the rear left side outside the cabin.



INDOOR LAMP

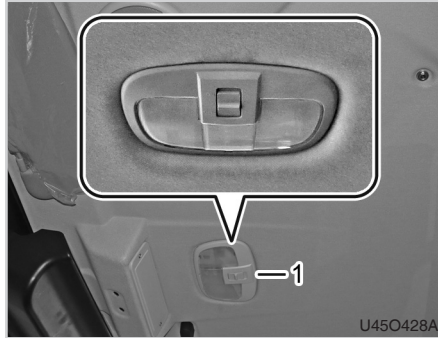

(1) Indoor Lamp

If you press the lens, the indoor lamp will be turned on. If you press it again, it will be turned off.

CAUTION

- **The room lamp can be operated without the key inserted. However, turning it on for an extended period of time can discharge the battery.**

SUN VISOR (IF EQUIPPED)

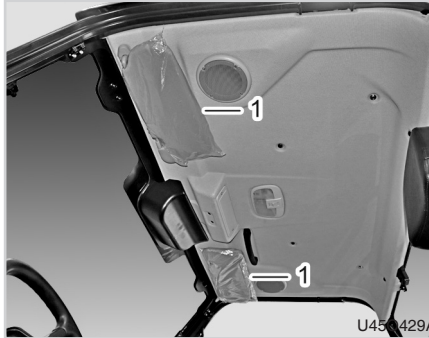

(1) Sun Visor

Pull it down to block the sunlight from the front. Keep it folded unless necessary.

VENT

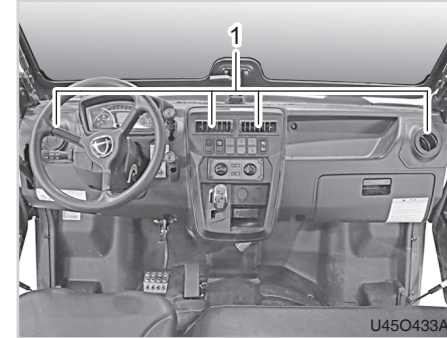

(1) Vent

It can be opened and closed through manual operation and the wind direction of the air conditioner or heater can be adjusted.

BLUETOOTH PLAYER/RADIO (IF EQUIPPED)

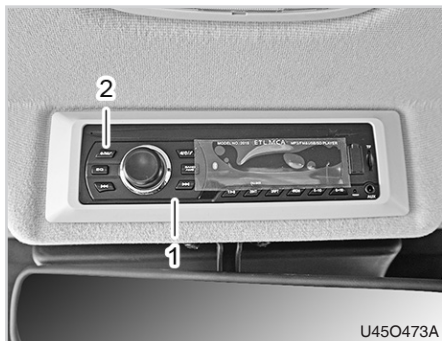

(1) Bluetooth Player/Radio
(2) Power Switch

This vehicle is equipped with a Bluetooth player which has an audio/radio function and wireless LAN communication. Using the Bluetooth function, it is possible to pair and use it with other Bluetooth enabled devices. For detailed information, refer to the stereo system's user manual.

⚠ CAUTION

- Working with the volume of the stereo system excessively high can affect the driver's concentration, leading to possible safety accidents.

INSIDE REAR VIEW MIRROR (IF EQUIPPED)



(1) Inside Rearview Mirror

The cabin is equipped with the inside rearview mirror for the driver's convenience.

Adjust the angle of the mirror before driving to secure for a clear rear view.

HEATER AND AIR CONDITIONER AIR CONDITIONER CONTROLLER

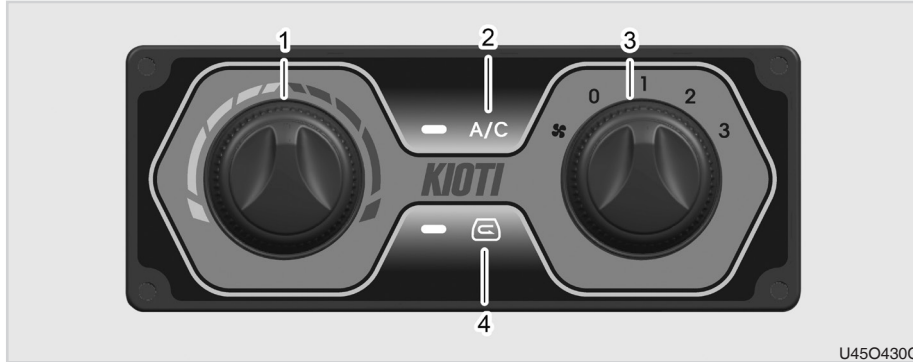

(1) Temperature Control Dial
(2) A/C ON/OFF Switch

(3) Fan Speed Control Dial
(4) Indoor/outdoor Switch

U45O430C

HEATER CONTROLLER (K9 2400F)



(1) Temperature Control Dial
(2) Fan Speed Control Dial

(3) Indoor/outdoor Switch

U45O455B

The heater and air conditioner should be operated with the engine running.

WARNING

- **Do not leave a child alone in the cabin. His/her health can be threatened as internal temperature rises rapidly in hot weather or on a sunny day.**
- **Use the fresh air mode in normal conditions and use the air recirculation mode only if necessary. Continued operation of the air recirculation mode can cause the inside to become stuffy, causing headaches, drowsiness, or frost on the windows. Do not operate the recirculation mode for an extended period of time.**

FAN SPEED CONTROL DIAL

U45O431B

The fan speed for the heater and air conditioner can be adjusted in three positions.

AIR CONDITIONER SWITCH (AIR CONDITIONER)

U45O432B

Press it to activate the air conditioner and press it again to deactivate the air conditioner.

The heater can be operated by the temperature control switch and fan speed control switch.

TEMPERATURE CONTROL SWITCH (AIR CONDITIONER)

U45O434B

The desired temperature can be set by adjusting this dial. Warm air flows out by turning it clockwise (red), and cool air flows out by turning it counter-clockwise. (Blue)

The temperature control dial only controls the amount of air flowing through the heater and air conditioner.

Therefore, unnecessary load can be applied to the air conditioner if this dial is set to the high temperature with the A/C in operation.



WARNING

- *If you sleep with the air conditioner or heater in operation, you may be suffocated to death.*
- *If keeping the A/C on for an extended period of time, inside air can become impure. Therefore, draw outside air and ventilate the cabin regularly.*

CAUTION

- **Keep the windows closed while the A/C is in operation for effective operation.**
- **Turn off the air conditioner for better engine power when the work load rapidly increases.**
- **When the UTV is stationary and being used in high load work, reduce the A/C operation period as the engine may be overheated.**
- **Make sure you operate the air conditioner once or twice a month in winter season to prevent refrigerant leakage and facilitate the compressor lubrication for durability of the A/C components.**
- **If the UTV has been parked under strong sunlight for a long period of time, open the windows to ventilate the cabin before operating the A/C.**

AIR CONDITIONER MAINTENANCE

Make sure to follow the instructions below to keep the air conditioner in the best condition:

1. Operation in winter season:

During the winter time, run the air conditioner once or twice every month to prevent refrigerant leakage and corrosion in the air conditioner system and to facilitate oil circulation in the compressor in order to prevent malfunction.

The A/C does not operate when the air temperature is below 2°C. Therefore, warm the inside air by operating the heater in order to be able to operate the A/C.

2. Air conditioner condenser care:

If there is foreign material in the A/C condenser and engine radiator, their cooling performance may be deteriorated. Therefore, always keep them clean for their optimal cooling performance. When cleaning the core of the condenser, use

a soft brush and water carefully not to bend it.

3. Operation in summer season:

Make sure to check the tension of the A/C belt before using the A/C frequently.

CAUTION

- The A/C system is charged with new refrigerant that does not destroy the ozone layer. Be careful when servicing the A/C system.
- Do not use unspecified refrigerant and compressor oil, or the air conditioner system could be seriously damaged.
- The performance of the A/C becomes poor when the refrigerant is insufficient. However, charging the air conditioner with excessive refrigerant affects its performance negatively. Therefore, have the system checked by a KIOTI Dealer if malfunction is found.

SPECIFICATIONS FOR A/C REFRIGERANT AND LUBRICANT

Item	New refrigerant	Compressor oil
Type	R-134a	UCON488
Charging amount	0.65 kg	265cc

WARNING

- *Have the air conditioner serviced by a qualified service personnel. If it is serviced by an unqualified person, he/she can be injured by the refrigerant under high pressure.*

TEMPERATURE CONTROL SWITCH (HEATER)



4

Adjust this dial to set the desired heater temperature. The more clockwise you turn, the warmer the air comes out.

CIRCULATION OF INDOOR AIR AND INFLOW OF EXTERNAL AIR TIRE



(1) Ventilation port changeover switch

When the air conditioner is running, indoor air can be circulated or outside air can be introduced. Even if indoor air circulation is selected, the inflow of outside air cannot be completely prevented. When selecting external air inflow, 100% external air is introduced.

⚠ WARNING

- *The cabin is not designed for spraying pesticides and has no function to prevent the inflow of contaminated external air into the interior.*

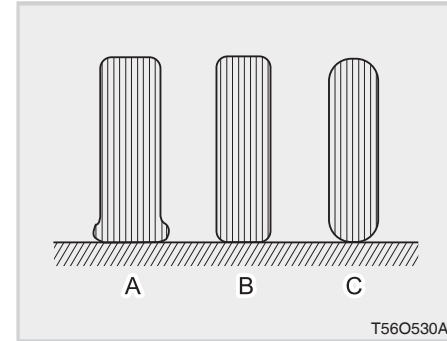

(A) Insufficient
(C) Excessive

(B) Standard

Though the tire inflation pressure is factory-set to the prescribed level, it naturally drops slowly in the course of time. Thus, check it everyday and inflate as necessary.

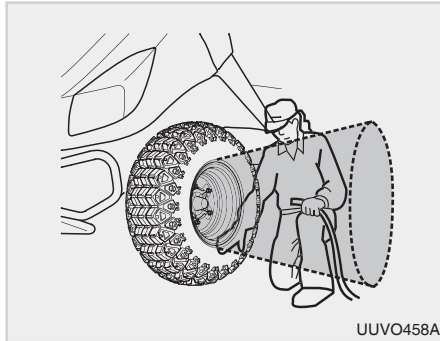

1. Always check the tire inflation pressure before driving. It is possible to check the inflation pressure roughly by checking the tires visually and tapping them (refer to the figure above).
2. Check if the wheel nuts are firmly tightened and tighten them as necessary before driving. Driving with loose wheel nuts can lead to a serious accident.

⚠ WARNING

- *Do not use tires larger or smaller than specified.*
- *Do not disassemble or assemble the tire. If it is necessary to disassemble/assemble the tire, let a qualified service person perform the work.*
- *The tire rims can fall out of the tires. Therefore, stay out of its way when checking or inflating tires.*

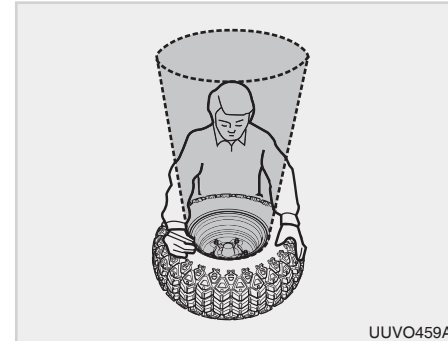

4

⚠ WARNING

- *Do not weld or apply heat to the tire rim or disc. The tire can explode due to the rapidly increased pressure in the tire.*
- *Check tires for inflation pressure, damage, deformation, and extended wear on lug and damage of the rim and disc. Also, check if the wheel bolts, rim bolts, and nuts are loose.*



PROPER INFLATION PRESSURE

Always maintain the proper tire inflation pressure. Make sure the tire pressure does not exceed the pressure recommended in the manual.

[FOR STANDARD TIRES AND WHEEL NUT]

Item		Type	Inflation pressure (Max.)	Wheel nut torque	Remarks
Front	Work site	25x10-12	24 psi (1.69 kg/cm ²)	51~58 lb.ft (5.0~5.3 kgf.m)	
	ATV	25x10-12	24 psi (1.69 kg/cm ²)		
	Turf	26x10.5-12	20 psi (1.41 kg/cm ²)		
Rear	Work site	25x10-12	24 psi (1.69 kg/cm ²)	51~58 lb.ft (5.0~5.3 kgf.m)	
	ATV	25x10-12	24 psi (1.69 kg/cm ²)		
	Turf	26x10.5-12	20 psi (1.41 kg/cm ²)		

NOTE

- If tires with a different size from the ones specified are installed, contact the **KIOTI** dealer for the front/rear wheel speed ratio. Improper front/rear wheel speed ratio can result in excessive wear of the tires.

[FOR SPECIFIED TIRES AND WHEEL NUT]

Item		Type	Inflation pressure (Max.)	Wheel nut torque	Remarks
Front	ATV	25x10.0x12	32 psi (2.2 kg/cm ²)	36~38 lb.ft (5.0~5.3 kgf.m)	
	Tomahawk (with Aluminum wheel)	25x10x12		50~60 lb.ft (6.9~8.3 kgf.m)	
	Heavy duty	25x10x12		36~38 lb.ft (5.0~5.3 kgf.m)	
	Heavy duty (with Aluminum wheel)	25x10x12		50~60 lb.ft (6.9~8.3 kgf.m)	
	Turf	26x10.5x12		36~38 lb.ft (5.0~5.3 kgf.m)	
Rear	ATV	25x10.0x12	32 psi (2.2 kg/cm ²)	36~38 lb.ft (5.0~5.3 kgf.m)	
	Tomahawk (with Aluminum wheel)	25x10x12		50~60 lb.ft (6.9~8.3 kgf.m)	
	Heavy duty	25x10x12		36~38 lb.ft (5.0~5.3 kgf.m)	
	Heavy duty (with Aluminum wheel)	25x10x12		50~60 lb.ft (6.9~8.3 kgf.m)	
	Turf	26x10.5x12		36~38 lb.ft (5.0~5.3 kgf.m)	

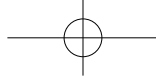

MEMO





OPERATION

PRE-OPERATION 5-2

DAILY INSPECTION 5-2

OPERATING THE ENGINE 5-2

STARTING THE ENGINE 5-2

CHECKING WARNING LAMPS AFTER
STARTING ENGINE 5-5

OPERATING PRINCIPLE OF PREHEAT
SYSTEM 5-6

STOPPING THE ENGINE 5-6

OPERATING THE VEHICLE 5-7

HOW TO DRIVE 5-7

WARMING UP 5-10

JUMP START 5-11

STOPPING 5-12

PARKING 5-13

SHIFTING 5-14

DRIVING ON SLIPPERY SURFACES 5-14

TURNING 5-15

DRIVING ON SLOPE 5-16

DRIVING IN FOREST 5-17

DRIVING THROUGH WATER 5-18

DRIVING BACKWARD 5-19

DRIVING ON ROAD 5-19

TRANSPORTING CARGO 5-20

CAUTIONS WHEN USING ELECTRIC POW-
ER STEERING 5-22

UNLOADING 5-23

TOWING TRAILER 5-24

TRANSPORTING 5-25

4WD OPERATION 5-26

DIFFERENTIAL LOCK OPERATION 5-27

TAILGATE (BACK DOOR) 5-28

5

5



PRE-OPERATION DAILY INSPECTION

It is a good practice to know the condition of your vehicle before you start it. You should do routine check before each use.

CAUTION

- **Stop the vehicle on level ground, stop the engine and apply the parking brake before checking or servicing the vehicle.**
- **For refueling, refer to the chapter "Maintenance."**
- **Read information titled as "Danger", "Warning", and "Caution" thoroughly for the safe operation.**

CHECK ITEM

- Check the engine oil level.
- Check the engine coolant level.
- Clean the radiator grille.
- Check the air cleaner filter.
- Check the brake pedal.
- Check the gauges and indicators on the instrument panel.
- Check the headlamps and turn signal lamps.
- Check the fuel level.
- Visually check the tire inflation pressure and wheel nut tightness.

For more information, refer to the chapter "Maintenance."

OPERATING THE ENGINE STARTING THE ENGINE

WARNING

To avoid accidents:

- ***Be sure to read and understand the warning and caution decals on the vehicle thoroughly.***
- ***Run the engine only in a well-ventilated area, or you can be suffocated by exhaust gas.***
- ***Never start the engine unless you are on the driver's seat. The vehicle can abruptly start off, resulting in an injury or accident.***

IMPORTANT

- **Using an additive so the engine will start more easily can damage the engine. And it will not be covered by warranty.**
- **To protect the start motor and battery from damage, never try to start the engine for over 10 seconds consecutively.**

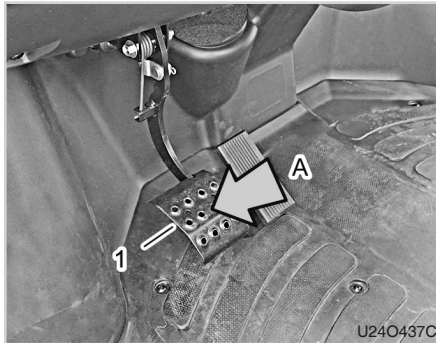

(1) Brake Pedal
(A) Depress

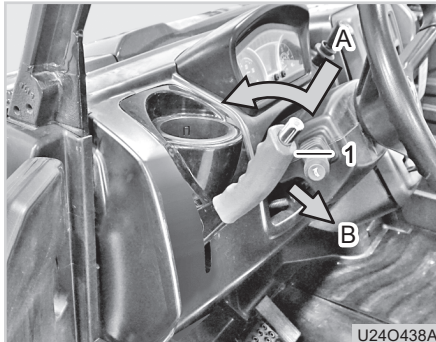

(1) Parking Brake Lever
(A) To deactivate it, hold the button down while pushing upwards
(B) To fix it in place, pull downwards

1. Make sure there is no obstacle around the vehicle.
2. Sit on the driver's seat and wear your seat belt, make sure that the parking brake lever is engaged, and then press the brake pedal.

NOTE

- The parking brake indicator on the instrument panel comes on while the parking brake is engaged. It goes off when the parking brake is released.
- The engine will not start unless the brake pedal is depressed.



(1) Shift Lever

3. Check that the shift lever is in the "N" (Neutral) position.

NOTE

- The vehicle is equipped with the safety switch for starting at the "N" position. Therefore, the engine will not start unless the gearshift lever is in neutral position and the brake pedal is depressed.

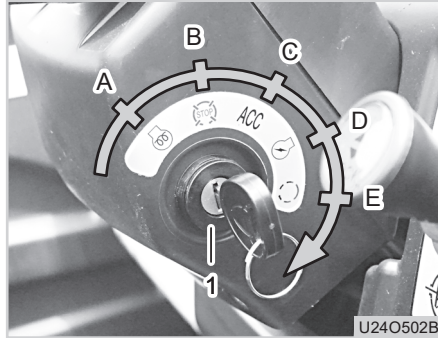

U24O502B

- (1) Key Switch (A) Preheat (B) Stop
(C) ACC (D) ON (E) Start

4. Insert the key into the key switch and turn it to the "ON" position.

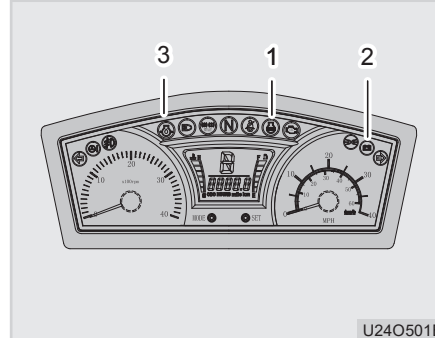

U24O501B

- (1) Glow Plug Indicator
(2) Battery Charge Warning Lamp
(3) Oil Pressure Warning Lamp

5. Check that the following lamps are turned ON.

- Charge warning lamp
- Oil pressure warning lamp
- Glow plug indicator (9 sec.)

6. Turn the key to the "START" position as soon as the glow plug indicator goes off.

⚠ WARNING

- **Never operate the start motor for 10 consecutive seconds as it consumes a lot of battery power. If the engine cannot be started within 10 seconds, wait for 30 seconds and try again.**
- **When trying to start the engine again, make sure that the fly-wheel is stopped in advance.**
- **Do not turn the key switch to the "START" position while the engine is running.**

7. When the engine is started, release the key. The key switch is automatically returned to the "ON" position.

8. After the engine is started, let the engine run for approx. 3 to 4 minutes (10 minutes in cold weather) to warm up the engine. (Refer to "Warming up" page 5-10 for details)



CHECKING WARNING LAMPS AFTER STARTING ENGINE

9. Check to see that all the warning lamps on the instrument cluster turn "OFF". If any lamp remains ON, immediately stop the engine, and contact your local **KIOTI** dealer for assistance.

IMPORTANT

- **It is not recommended to operate the vehicle full speed or excessive load when new. Doing so can harm the overall service life of the vehicle.**

Break in the vehicle by driving with light work loads or at a maximum of 3/4 throttle for the first 20 hours.

1. If the oil pressure warning lamp does not go off in 4 to 5 seconds after the engine is properly started, stop the engine immediately and check the engine oil level. If the engine oil level is within safe operating limits, contact your local **KIOTI** Dealer.

WARNING

- ***The engine can be severely damaged if it is run with the oil pressure warning lamp ON.***

2. If the charge warning lamp does not go off in 4 to 5 seconds after the engine is properly started, it means that the battery is not being properly charged. Have the charging system, such as the battery and alternator, serviced.
3. Refer to "Instrument panel" in chapter 4 for detailed information about other indicators and lamps.

WARNING

- ***Driving the vehicle for an extended period of time with the charge warning lamp ON, the battery can be discharged and the vehicle's electrical system can be damaged.***



OPERATING PRINCIPLE OF PRE-HEAT SYSTEM

1. When the key switch is turned to the "ON" position, the glow plug indicator comes on for 9 seconds and then goes off. The engine should be started within 3 seconds after the glow plug indicator goes off.
2. After the engine is started, post-heat is performed without any indicating lamp on. The post-heating function keeps the glow plugs activated for approx. 20 seconds after the engine is started in order to enhance the engine combustion performance and reduce harmful emissions right after engine starts.
3. The preheat/post-heat function and glow plug indicator do not operate when the coolant temperature is 30 °C (86 °F) or higher. In this case, the engine can be started without the preheat operation.
4. In case extra preheating is needed, hold the key in (Ⓚ) position. Do not preheat more than 30 seconds.

STOPPING THE ENGINE

1. Make sure to reduce the engine rpm before stopping the engine.
2. Put the shift lever in the neutral position.
3. Apply the parking brake.
4. Run the engine at idle speed for approx. 2 to 3 minutes, and then turn the key switch to the "OFF" position to stop the engine.
5. Remove the ignition key.

WARNING

- ***Never touch the muffler or heat shield until the engine is sufficiently cooled down. Failure to do so could result in serious injury on burns.***

CAUTION

- **Apply the parking brake and remove the key from the key switch before leaving your vehicle. An unauthorized person or child can move or operate the vehicle, resulting in an injury or accident.**
- **This vehicle is equipped with a CVT (Continuous Variable Transmission). Therefore, the vehicle may roll down a slope if the parking brake is not engaged even though the shift lever is in the "H", "L" or "R" position.**

IMPORTANT

- **If the vehicle is operated for an extended period of time, idle the engine at low speed for 2 to 3 minutes in order to cool down the engine before shutdown.**



OPERATING THE VEHICLE HOW TO DRIVE

⊕ IMPORTANT

- When leaving the vehicle, make sure to remove the key after turning off all the electrical systems.
- Also, be careful not to leave the utility vehicle unattended as the same key is used for all KIOTI vehicles. It can be stolen.
- The horn, turn signal lamps and hazard warning lamps can be operated without the key in the key switch. Therefore, special care must be taken to prevent the battery from discharging.



(1) Seat Belt

1. Sit down on the seat and fasten the seat belt.

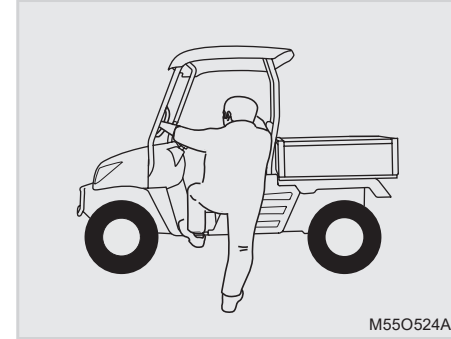

Enter or leave the vehicle through the left-hand door.

5

⚠ WARNING

- **Do not jump on or off the vehicle. It may cause injuries. Always face the vehicle, use the hand rails and steps, and get on or off slowly. Maintain a minimum three point contact to avoid falling. (Both hands on rails and one foot on the step, or one hand on the hand rail and both feet on the steps)**



⚠ WARNING

- **Fasten the seat belt firmly when you are seated in the vehicle.**
- **The seat belt can reduce or prevent injuries in an accident. Make sure to wear the seat belt during driving. Also, be sure the seat belt is not twisted. A twisted or improperly fastened seat belt may not protect an occupant properly, in an accident.**
- **The seat belt should go around your pelvis or as low as possible, not your waist or abdomen. Otherwise, the seat belt cannot protect you properly.**
- **Children under age 16 or who doesn't have a driver's license should not drive this vehicle.**
- **Children under age 5 should not ride on this vehicle even in the passenger seat.**



(1) Shift Lever

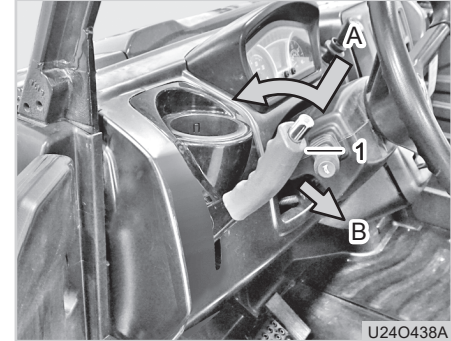

(1) Parking Brake

- (A) To deactivate it, hold the button down while pushing upwards
- (B) To fix it in place, pull downwards

2. Start the engine after checking that the shift lever is in the neutral position.

3. Release the parking brake.

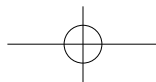



(1) Shift Lever

"H": High Speed

"L": Low Speed

"N": Neutral

"R": Reverse

4. Place the shift lever to the "H" (High speed) or "L" (Low speed).
5. Depress the accelerator pedal gradually to start off the vehicle.
6. The 4WD system can be used as necessary.

⚠ CAUTION

- Avoid abrupt acceleration or braking for safe driving.
- When driving on a steep hill or loading or unloading the vehicle, set the shift lever into the "L" position or the 4WD/2WD lever into the "4WD" position in advance.
- Practice starting and stopping the vehicle with the pedals and levers until getting used to these controls.
- Place the shift lever into the "L" position when driving on a soft or bumpy surface or carrying a heavy load.

⊕ IMPORTANT

- Do not shift the gear when the vehicle is moving or the engine is running at a high idling speed. To stop the vehicle, depress the brake pedal, and then move the shift lever.
- Shifting at a high idling speed can wear the gears.

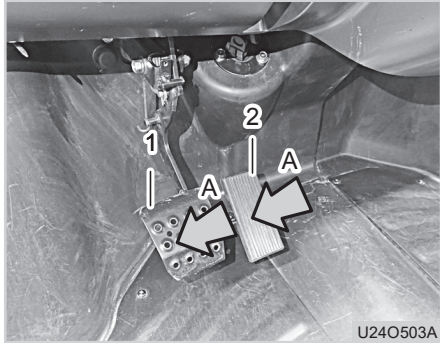

(1) Brake Pedal (2) Accelerator Pedal
(A) Depressed

7. To stop the vehicle, release the accelerator pedal and depress the brake pedal.

WARMING UP

It is recommended always to warm up the engine before driving in order to maintain the durability of the engine and prevent malfunction of the engine.

Warming up the engine can ensure that each part in the engine is properly lubricated and each hydraulic part is in a perfect condition in order to prevent malfunction in the engine as well as the hydraulic system.

HOW TO WARM UP ENGINE

1. Start the engine and run it at a low speed and without load for approx. 3 to 4 minutes.
2. In cold weather, increase the warming up time to 10 minutes.
3. If it is very cold, warm up the engine for approx. 15 minutes.
4. The engine throttle can be open for 50 % in order to shorten the warming up time.

5. The engine is sufficiently warmed up when the temperature gauge on the instrument panel indicates 1/4 of the normal temperature range, regardless of the warming-up time.
6. Do not increase the work load or driving speed rapidly after starting work.
7. Run the engine without load or idle for approx. 2 to 3 minutes before stopping the engine after work.

WARNING

- ***Warming up the engine excessively increases fuel consumption and affects the durability of the vehicle negatively.***
- ***Never warm up the engine and leave the vehicle for an extended period of time. It can cause fire and an accident.***



JUMP START

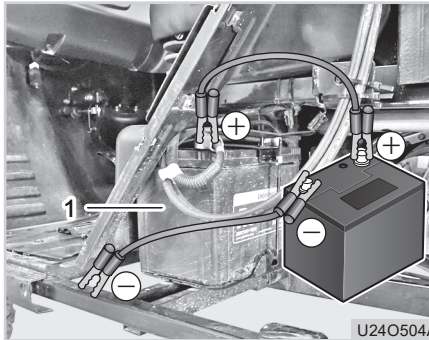
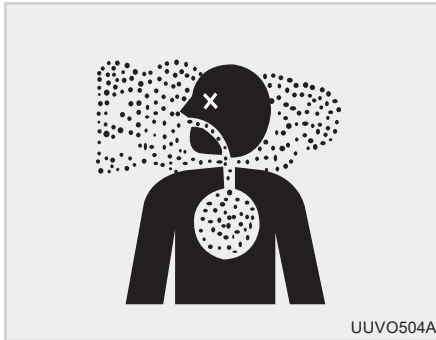

(1) Battery

CAUTION

- **Avoid running the engine in an enclosed area. Inhaling emissions can harm your health.**
- **If it is unavoidable to run the engine in an enclosed area, make sure to ventilate the area properly and take proper actions to avoid inhaling emissions.**

If the battery is discharged and the engine cannot be started, it is possible to start the engine by connecting the discharged battery to a battery from another vehicle or other extra battery.

1. Check that the voltage of the discharged battery is the same as the voltage of the other vehicle for jump start. (Specification for this vehicle: 12 V)
2. Check the length of the jumper cables and position another vehicle near the vehicle with the discharged battery. Then, put the shift lever in the neutral position, apply the parking brake, and stop the engine.
3. Wear protective glasses and gloves and open the battery cover of both vehicles. Remove the battery terminal cover as necessary.
4. Connect the alligator clips on both ends of the red positive cable to the positive terminals of both batteries.



5. Connect one clip of the black negative cable to the negative terminal of the normal battery and the other clip to the vehicle body with the discharged battery. Make sure to connect the clip to the body part without paint.
6. Start the engine of the vehicle with the normal battery.
7. Start the engine of the vehicle with the discharged battery.
8. Disconnect the black cable from the negative battery terminals of both of the vehicles.
9. Disconnect the red cable.
10. Run the engine for at least 30 minutes to charge the discharged battery.
11. If the battery is discharged again, replace it or check the charging system, such as the alternator.

STOPPING

Depress the brake pedal to control the driving speed.

1. Release the accelerator pedal completely.
2. Depress the brake pedal evenly and firmly.

WARNING

- ***The stopping distance increases when loaded with cargo or towing a trailer. In this case, drive at a low speed and always consider the actual stopping distance.***

NOTE

- Always check the brake function before operating the vehicle.
- This vehicle is equipped with the parking brake system and main brake system separately for safety. The parking brake should be used in an emergency, such as brake pedal failure.
- Never depress the accelerator and brake pedals simultaneously.



PARKING

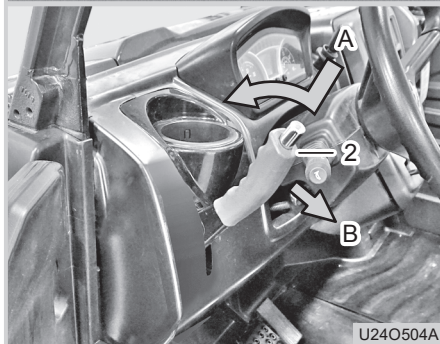
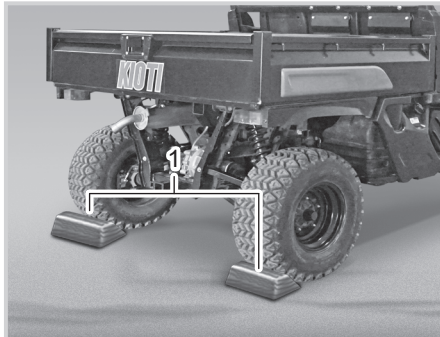

- (1) Chock (2) Parking Brake Lever
 (A) To deactivate it, hold the button down while pushing upwards
 (B) To fix it in place, pull downwards

When parking, make sure to pull up the parking brake fully.

The parking brake in the vehicle is equipped with separate disc and pad in order to enhance safety. Make sure to use the parking brake in emergencies, such as brake pedal malfunction, during driving.

⚠ WARNING

- **Never park on a slope with only the transmission engaged. The vehicle may roll down, leading to an accident.**
- **If it is unavoidable to park on a slope and leave the vehicle, apply the parking brake and chock the wheels.**
- **Never park the vehicle on a steep slope. A serious accident can occur.**

⚠ WARNING

To avoid possible injury, death or loss of property from a machine runaway:

- **With the engine off, the vehicle may move unexpectedly regardless of the gear shift position.**
 - **Before leaving the vehicle certainly apply the parking brake to prevent machine runaway.**
- ※ Only CVT model.

SHIFTING

This vehicle is equipped with the CVT (Continuous Variable Transmission) and the shifting operation is automatic according to the accelerator pedal operation and outer load condition.

Make sure to move the shift lever to the "H", "L" or "R" position when the vehicle is stationary. In order to stop the vehicle, release the accelerator pedal and depress the brake pedal as necessary.

WARNING

- ***If moving the shift lever to the "H", "L" or "R" position while the vehicle is moving or the accelerator pedal is depressed, the internal gears related to the shifting operation can be severely damaged.***

DRIVING ON SLIPPERY SURFACES



It is possible that the vehicle can skid with its rear side sliding to one side when driving on a muddy, icy or slippery road. Therefore, when driving in this circumstance, observe the following:

1. Slow down before you enter a slippery area.
2. Before entering a slippery area, move the shift lever to the "L" position and 2WD/4WD lever to the "4WD" position as necessary.

3. Avoid abrupt acceleration and turning during driving on a slippery road.
4. If the vehicle cannot move forward due to spinning wheels, stop the vehicle, engage the differential lock lever and then try again.

WARNING

- ***Abrupt braking or acceleration in the 2WD operation on a slippery surface can make the rear wheels slide to one side, resulting in the vehicle skidding. Make sure to use the 4WD in advance in this case.***
- ***When the vehicle starts to skid with the rear wheels spinning, release the accelerator or brake pedal and turn the steering wheel to the spinning direction immediately.***
- ***If it is necessary to brake the vehicle abruptly on an icy or slippery road, depress the brake pedal for several times.***

**⚠ WARNING**

- *It is recommended to use the 4WD on a slippery road. Using the 4WD can increase the driving force of the wheels as well as the braking performance on a slippery road. Also, it reduces a chance of the vehicle skidding at abrupt braking.*
- *It is a best measure to drive at a low speed with the 4WD and low gear position selected on a slippery surface. Otherwise, the vehicle can roll over or collide.*

TURNING

Before entering a curved road, slow down your speed. Turning at a high speed can lead the vehicle off the course, resulting in a severe accident.

Be careful not to lose balance during turning. The driver and all occupants should wear the seat belts. If the differential lock system is used during turning on a normal road with sufficient friction, the durability of the internal gears related to the differential system can be damaged. Also, there is a high chance that the vehicle can over turn due to poor steerability.

If cargo is loaded onto the cargo bed too high, the center of gravity of the vehicle gets high and the centrifugal force increases when turning. Therefore, drive slower when turning.

⚠ WARNING

To prevent an accident due to loss of steering control:

- *If turning at a high speed, the vehicle can turn over.*
- *Never use the differential lock system when turning at a high speed and even at a low speed. A serious accident can occur.*



DRIVING ON SLOPE UPHILL AND DOWNHILL

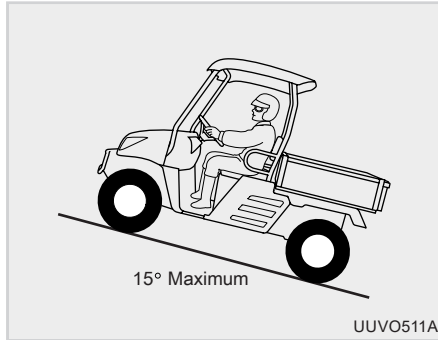

1. Move the shift lever into the "L" position before driving uphill. Also, select the 4WD as necessary depending on road surface conditions.
2. Avoid driving on a slope of 15° or more. Drive the vehicle at a low speed so that the engine is not applied with excessive load.

3. It is hard to steer the vehicle and the front section of the vehicle can be lifted off the ground when driving on a slope with excessive cargo loaded in the vehicle. In the worst case, the vehicle may roll over down the hill. Therefore, avoid carrying excessive load when driving on a slope and drive backward uphill if necessary.
4. Use the engine braking function of the CVT as an auxiliary means of braking. Shift the lever into the "L" (Low speed) position when driving on a hill or a bumpy area so that the vehicle can utilize more power and enhance durability of the CVT belt and pulley.
5. Never drive backward downhill with cargo loaded. The vehicle can roll over.

HILL INCLINED SIDWARD

1. When driving on a road inclined sideward, be extra careful not to let the vehicle overturn sideward.
2. The best measure to prevent overturn on a road inclined sideward is driving at a low speed.
3. Never drive on a road inclined sideward for 12° or more.
4. If starting to lose balance while driving forward on a road inclined sideward, turn the steering wheel to the downhill direction to gain control of the vehicle again.
5. Be extra careful when driving with cargo loaded.

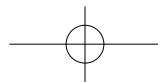

**⚠ WARNING**

- *When driving on a road inclined vertically or sideward, make sure to drive at a low speed. Otherwise, the vehicle can roll over, leading to a serious accident.*
- *Driving with excessive load on a slope can lead to overturn.*
- *Always wear the seatbelt and safety gears, such as a helmet, when driving on a slope.*

DRIVING ON DOWNHILL ROADS**⚠ WARNING**

- *Continuously stepping on the brakes while driving on a downhill road causes braking performance to decrease due to overheating of the braking device and can lead to accidents. On long downhill roads, be sure to use a lower gear and gradually lower your speed using the foot brake.*

DRIVING IN FOREST

1. Drive at a low speed when driving in a mountainous area or through a forest.
2. Wear protective gear, such as a helmet to avoid an injury by branches.
3. Be sure to wear the seat belt to minimize a chance of injury by collision with a tree or rock.



DRIVING THROUGH WATER



This vehicle can go through water as high as the floor of the vehicle.

Make sure to check the depth of water before entering. When driving through deep water, the wheels may lose traction so that you cannot control the vehicle, leading to an accident. Make sure to observe the specified water depth limit.

Never drive through swift water flow even though its depth is below the height of the vehicle floor.

Consider the following when driving through water:

1. Check the depth and speed of water or water flow before entering it.
2. Avoid a steep path when driving through water.
3. Be careful not to hit a rock or obstacle and drive at a low speed.
4. Drive slowly with 4WD.
5. After driving through water, depress the brake pedal several times to dry the brake disc for normal brake operation.

WARNING

- ***Driving through water without knowing depth, speed and bottom condition of water flow is very dangerous and can lead to a drowning accident.***
- ***If driving on a slope or at a high speed with the brake wet after driving through water, the brake system may not function properly, leading to an accident.***

CAUTION

- **Salty water corrodes paint and exterior parts of the vehicle. Make sure to wash the vehicle thoroughly with tap water.**
- **If any part is corroded by salty (sea) water, it may not be covered by warranty.**

NOTE

- It is required to service the vehicle after driving through water. Pay special attention to the engine oil, transmission fluid, front/rear differential gear cases and grease fittings.



DRIVING BACKWARD

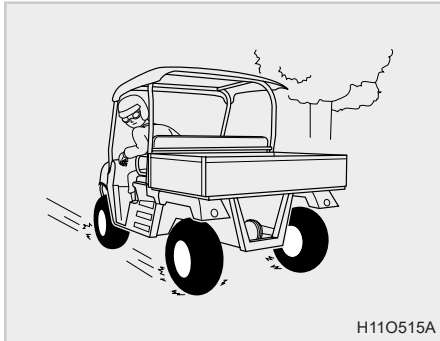

Consider the following when driving backward:

1. Drive backward at a low speed. To stop the vehicle, depress the brake pedal gently.
2. Avoid abrupt turning and driving down the slope backward.
3. Never depress the accelerator pedal abruptly and pay close attention to the surroundings before driving backward.

WARNING

- *If precautions are not taken during driving backward, a serious accident can occur. Check if there is any obstacle or person behind the vehicle before driving backward. Also, keep the speed slow.*

DRIVING ON ROAD

Observe the following when driving on a road:

1. It is recommended to attach the "Safety lamp kit" (If equipped) from **KIOTI** when driving on a public road.
2. If the vehicle is equipped with the turn signal lamps, use them during driving. If not, inform other drivers of your intended direction with hand signals.
3. Use the low beam when driving at night. Otherwise, the headlamps can disturb the approaching vehicle's visibility.

**⚠ WARNING**

- ***When driving on a road, make sure to install the “Safety lamp kit” supplied by KIOTI and observe the applicable regulations and laws. If the vehicle is not equipped with the “Safety lamp kit”, there will be no brake lamps, turn signal lamps and tail lamps on the vehicle. In this condition, it is very dangerous to drive on a road.***
- ***In some countries or states, it is illegal to drive a UTV on public roads. Be aware of traffic laws before driving.***

TRANSPORTING CARGO

1. Distribute cargo evenly onto the cargo bed when driving.
2. For the vehicle without the hydraulic dump kit (If equipped), it is hard to raise the cargo bed if the load is concentrated to the front side of the vehicle.
3. The max. load limit for the vehicle is 500 kg (1100 lbs). Make sure to keep under this specified limit. Otherwise, steerability and braking performance are degraded and you may lose control of the vehicle, leading to a severe accident.
4. Load cargo only up to half of the load limit when driving on a steep, bumpy or slippery road.
5. When loading wide or long objects, secure them with ropes firmly. The vehicle should be equipped with the rear screen (If equipped) so that such objects do not hit the back of the driver.
6. When loading heavy material, such as sand and earth, distribute it evenly in the cargo bed and do not pile it over the side frame of the cargo bed.
7. Wet sand weighs at least twice as much as dry sand. Therefore, load sand less if it is wet.
8. Make sure to distribute cargo evenly in the cargo bed. Otherwise, the vehicle can overturn.



9. Never let anyone ride on the cargo bed. It can lead to a serious accident.
10. The brake system is applied with excessive load when driving on a slope with excessive cargo. Therefore, load only up to half of the specified load limit when driving on a slope.

11. If an object, such as a rock, is loaded, but not secured onto the cargo bed, driving on a slope, abrupt starting-off or abrupt braking can damage the cargo bed parts and lead to an accident due to the object rolling on the cargo bed. Make sure to secure any cargo firmly.

WARNING

- *If loading cargo excessively or unevenly, you can lose steerability and braking control, resulting in a severe accident. Make sure to keep under the specified load limit and observe relevant regulations.*
- *Avoid over speed driving, abrupt acceleration and abrupt starting-off in order to prevent accidents when the vehicle is loaded.*
- *Make sure to secure cargo firmly so that it does not hit the driver. Install the rear screen (If equipped) if necessary.*



CAUTIONS WHEN USING ELECTRIC POWER STEERING



(1) Electric power steering wheel

1. Electric power steering is a device which uses an electric motor to enable the driver to operate the steering wheel more easily. The system was designed to minimize driving-related fatigue. Electric power steering works normally only when the motor is running.
2. When cargo is loaded in the cargo box, the front part of the vehicle becomes lighter, resulting in potential risks while driving. In this

case, operate the steering wheel with the vehicle running at a low speed.

3. If the vehicle is equipped with electric power steering, do not keep the steering wheel turned all the way to the right or left with the vehicle stopped. When the anti-overload system is activated, it becomes more difficult to turn the steering wheel toward both extremes. However, this is for the driver's safety; it is not a malfunction. The vehicle will return to its initial state over time, and there is no effect on vehicle operation.

⊕ IMPORTANT

The following phenomena are normal if no warning lamps on the instrument cluster are turned on when they occur.

- During the diagnosis phase of the electric power steering system immediately after starting the engine, the steering wheel becomes heavy (for two seconds); then, the steering function returns to normal.
- If an error is detected in the electric power steering system, the system stops to prevent a fatal accident. In this case, the steering wheel may suddenly feel much heavier.

**⊕ IMPORTANT**

The following phenomena are normal if no warning lamps on the instrument cluster are turned on when they occur.

- A noise occurs due to the connection with the relay when the engine is turned on or off; however, this is a normal sound which confirms that power steering is in operation.
- A noise may occur due to the rotation of the motor when the vehicle stops or when the steering wheel is turned while driving at a low speed; however, this sound is a normal part of vehicle operation.

UNLOADING

(1) Dumping Lever
(A) Pull Up

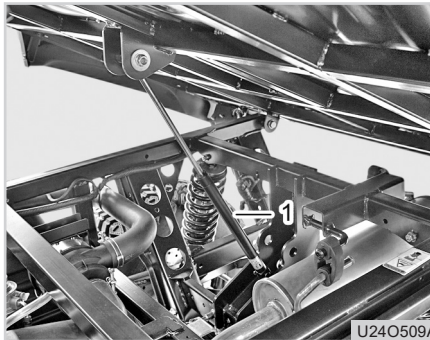

(1) Gas Spring Kit

1. Open the tailgate with both hands. Be careful as the tailgate can open abruptly due to cargo on the cargo bed.
2. To raise the cargo bed, pull up the handle with one hand while turning the latch lever with the other hand.
3. Never apply excessive force to raise the cargo bed as you may get injured. In this case, unload some cargo on the front with a shovel or other tools, before trying again.

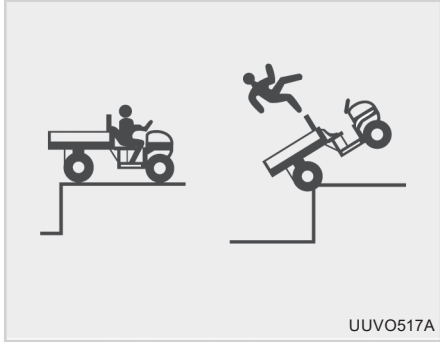

⚠ WARNING

- ***A part of your body may get between the vehicle body and cargo bed or your waist can get injured while raising or lowering the cargo bed. Never apply excessive force to raise the bed and pay special attention to install the support rod properly.***

⚠ WARNING

- ***Make sure to check the ground condition before driving backwards to unload.***
- ***Apply the parking brake firmly before unloading.***
- ***Never drive the vehicle with the cargo bed raised. The cargo bed can fall accidentally, resulting in an accident.***

TOWING TRAILER

This vehicle is equipped with a 2-inch square hitch receiver in the back as standard. Be careful of the following when towing a trailer

1. This vehicle can tow a trailer and cargo with their weight of up to 590 kg (1,300 lbs). You can lose control of the vehicle, leading to an accident if towing more than specified.
2. The max. vertical load applicable to the tow hitch is 50 daN (110 lbs) which is 10% of the total towing load limit. If this specification is not met, the vehicle can turn over backward.
3. It is very hard to drive backward with a trailer connected. Keep the speed low.

**[Tips for driving backward with trailer]**

If a trailer is about to go out of a correct course during driving backward, turn the steering wheel to the direction which the trailer goes then the trailer returns to its original course.

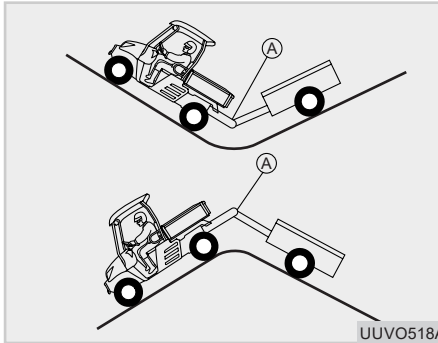

4. When driving over an excessively concave or convex surface, excessive stress is applied to the hitch connection. A ball-type hitch (A) is recommended in this case.

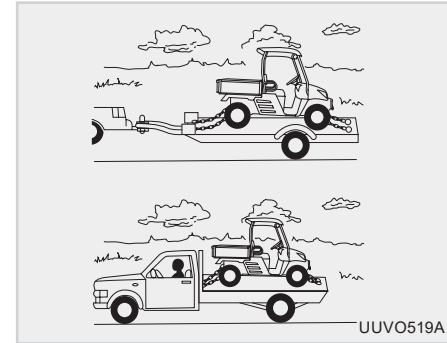
TRANSPORTING

1. Check the width of the cargo bed of a transporting vehicle or trailer.
2. Set ramps to the transporting vehicle firmly.
3. It is recommended to drive backward onto the transporting vehicle to drive out of it more easily later.
4. Make sure to set the shift lever to the "L" position and the 2WD/4WD lever in the "4WD" position.

5. After getting onto the transporting vehicle, apply the parking brake firmly and secure the vehicle onto the body frame or bracket of the transporting vehicle with chains or belts.
6. When transporting the vehicle on a road, set applicable decals to keep local regulations.
7. Always keep the total height in mind so that the vehicle top does not hit under a bridge or the top of a tunnel.

⚠ WARNING

- ***Make sure to secure the vehicle firmly during transportation.***
- ***The canopy, windshield or other components, which can be accidentally removed by wind during transportation, should be removed in advance before transportation and transported separately.***
- ***The above precautions should be kept in order to avoid a serious accident during transportation.***

4WD OPERATION

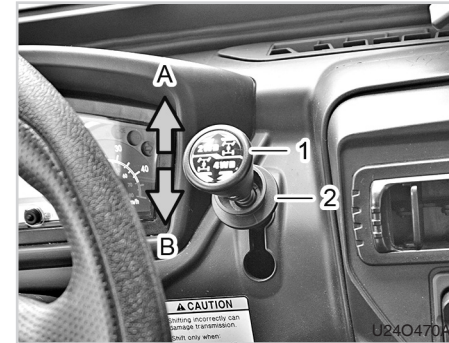

- (1) 2WD/4WD Shift Lever
 (2) Detent Knob
 (A) 2WD (B) 4WD

The rear wheels are driven in the 2WD mode while all the wheels are driven in the 4WD mode. Keep the following instructions to use the 4WD correctly:

1. It is recommended to use the 4WD when driving on a slippery, muddy or icy road, driving through water or driving to load or unload the vehicle to the transporting vehicle.



- When moving the 2WD/4WD lever, push up the detent knob with a finger and then move the lever.
- To operate the shift lever, depress the brake pedal and stop the vehicle completely. It is hard to shift when the vehicle is moving or the engine is running at a high idling speed. Moreover, abnormal noise may occur and parts related to the shifting operation can be damaged.
- Move the 2WD/4WD lever back to the "2WD" position as soon as the 4WD is not necessary. Prolonged use of the 4WD in a normal condition can increase the fuel consumption and decrease the durability of parts related to the power transfer system. It also affects the steering performance negatively.

- In some cases, it may be hard to move the 2WD/4WD shift lever out of the "4WD" position. This is because parts related to the shifting operation are firmly engaged. These parts can be released easily by changing the driving direction. (Forward or backward)

WARNING

- Never try to shift the gear while the vehicle is moving or the engine is running at a high speed. The power transfer system can be severely damaged and an accident can occur.***

DIFFERENTIAL LOCK OPERATION

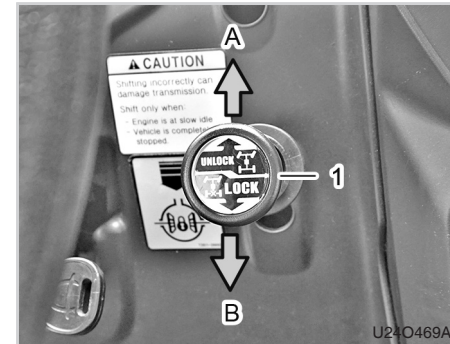

(1) Differential Lock Lever
(A) Unlock (B) Lock

5

On hard firm ground, the differential system should be unlocked to secure safe turning.

When the wheel on one side is on a slippery surface, such as mud or icy road, the wheels on a slippery surface lose traction and rotate fast while the wheel on a normal surface do not rotate, resulting in the vehicle stuck into its position. In order to prevent this situation, this vehicle is equipped with the differential lock system.



TAILGATE (BACK DOOR)

[DIFFERENTIAL LOCK SYSTEM]

The differential lock system is to connect the wheel on the left and right mechanically to rotate them at the same speed regardless of friction applied to them even on a slippery or bumpy road for better traction.



(1) Latch Lever



(1) Gate

1. When opening the tailgate, it can open abruptly due to cargo on the cargo bed. Therefore, support the upper side of it with both hands when pushing the latch lever.

2. Keep your feet as far as possible as any object can fall off the cargo bed when the tailgate opens abruptly.

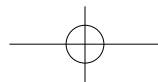



REPLACEMENT PARTS

ESSENTIAL REPLACEMENT PART 6-2

OILS AND FLUID	6-2
FILTERS	6-2
BELTS AND RUBBER PARTS	6-3
ELECTRIC PARTS	6-3

6

6

ESSENTIAL REPLACEMENT PART OILS AND FLUID

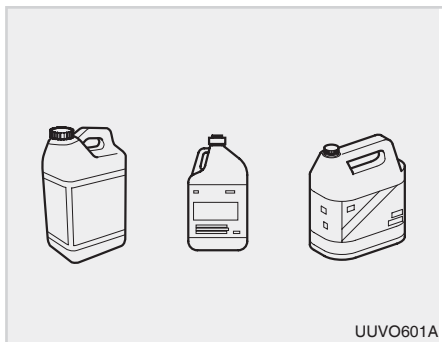

There are various types of oil and fluids used in this vehicle for the operation, lubrication, cooling and anti-corrosion of the vehicle.

If any oil or fluid is insufficient, degraded or contaminated, it can cause incorrect operation and seizure, resulting in damage of the vehicle.

In order to protect the vehicle properly and keep it in a perfect condition, make sure to refill or change the oil and fluid specified in accordance with the maintenance intervals. Refer to chapter 7 "Maintenance".

U.S.Gal. (L)

NO	ITEM	SPECIFICATION	CAPACITY
1	Engine Oil	SAE 15W40	0.85 (3.2)
2	Gear Box	Daedong : UTF 55 Shell : Donax-TD,	0.23 (0.9)
3	Front Differ.	Exxonmobil : Mobilfluid 424	0.16 (0.6)
4	Rear Differ.	Exxon Hydraul 560 BP : Tractran UTH	0.21 (0.8)
5	Grease	SAE multifunctional	A little
6	Anti-freeze	Ethylene glycol and water (50:50)	1.45 (5.5)
7	Brake Oil	DOT 3	-

FILTERS

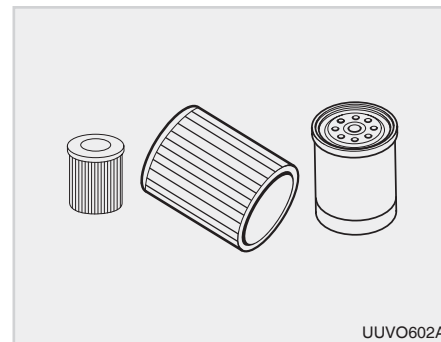

The various filters and air cleaner are consumables to filter foreign materials from oil and air. Make sure to check or replace these parts when changing oil.

NO	PART NO	DESCRIPTION	QTY
1	E5205-32091	Engine Oil Filter	1
2	84612-4316-0	Fuel Filter Element	1
3	UD23-2305A	Brake Pad (Front)	2
4	UD23-4305A	Brake Pad (Rear)	2
5	F6820-72531	A/C Belt	1

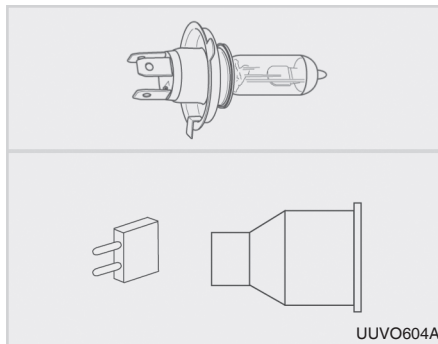
**BELTS AND RUBBER PARTS****ELECTRIC PARTS**

Rubber belts, hoses and boots get tender and cracked as they age. Continuous use of a belt, hose or boot in poor condition can result in failure, causing a serious problem to the vehicle. Make sure to replace such parts at the specified intervals in order to prevent accidents.

NO	PART NO	DESCRIPTION	QTY
1	EC11-0025A	Fan Belt	1
2	0052-2001A	CVT Belt	1
3	U3215-40011 (4pc)	Brake pad	2

NO	PART NO	DESCRIPTION	QTY
1	UD26-0065A	Slow Blow Fuse	1
2	T5210-68652	Fuse 5A	6
3	T5210-68662	Fuse 10A	1
4	T5210-68672	Fuse 15A	2
5	T5210-68682	Fuse 20A	5
6	T5210-68692	Fuse 25A	3
7	T5210-68702	Fuse 30A	5
8	TF15-0187A	Fuse 25A	1

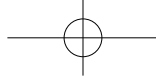

MEMO





MAINTENANCE

7

MAINTENANCE CHECK LIST 7-3

- DAILY CHECK CHART 7-3
- MAINTENANCE INTERVAL TABLE 7-4

LUBRICANTS 7-6

DAILY INSPECTION 7-8

- ACCESS FOR SERVICE 7-8
- OPENING INSPECTION SHIELD (A)..... 7-8
- OPENING SEAT CUSHION (B)..... 7-9
- RAISING CARGO BED (C)..... 7-9
- APPLYING GREASE (D)..... 7-10
- CHECKING ENGINE OIL LEVEL (E)..... 7-12
- CHANGING ENGINE OIL AND FILTER (F) .. 7-13
- DUST VALVE (G)..... 7-14
- REPLACING AIR FILTER (H)..... 7-15
- CHECKING AIR HOSE AND CLAMP(I)..... 7-15
- CHECKING CVT BELT (J)..... 7-16
- CHECKING CVT DRIVEN PULLEY
CLUTCH BUTTONS (K) 7-18
- CHECKING FUEL FILTER(L)..... 7-19
- BLEEDING FUEL LINE (M) 7-20

- CHECKING INJECTION NOZZLE AND
FUEL INJECTION PUMP (N)..... 7-21
- CLEANING RADIATOR CORE (O) 7-21
- CHECKING COOLANT IN AUXILIARY
COOLANT TANK (P)..... 7-22
- CHANGING COOLANT (Q1) 7-23
- BLEEDING AIR IN COOLANT(Q2) 7-26
- CHECKING SPARK ARRESTER OF EX-
HAUST PIPE (IF EQUIPPED) (R)..... 7-27
- CHECKING AND CHANGING GEARBOX
OIL (S)..... 7-27
- CHECKING AND CHANGING FRONT
AXLE OIL (T) 7-29
- CHECKING AND CHANGING REAR
AXLE OIL (U)..... 7-31
- CHECKING DRIVE SHAFT AND CV
BOOTS (V)..... 7-32
- CHECKING STEERING RACK BOOTS
AND BALL JOINT (W)..... 7-33
- CHECKING BRAKE FLUID (X) 7-34
- CHECKING BRAKE PEDAL FREE PLAY (Y).. 7-34
- CHECKING BRAKE PAD (Z)..... 7-35
- CHECKING PARKING BRAKE (AA)..... 7-36



MAINTENANCE

ADJUSTING SUSPENSION (AB)	7-37	REPLACING A/C FILTER(AQ)	7-50
CHECKING SUSPENSION SHOCK AB- SORBER (AC)	7-38	AIR CONDITIONER BELT TENSION (AR)...	7-51
BATTERY (SEALED) (AD)	7-38		
REPLACING HEADLAMP BULB (AE)	7-42		
CHECKING AND REPLACING FUSE (AF) ..	7-42		
MAIN FUSE (SLOW-BLOW FUSE) (AG) ...	7-44		
ALIGNING WHEEL AND CHECKING WHEEL NUT (AH)	7-44		
CHECKING DIFFERENTIAL LOCK CABLE (AI)	7-45		
CHECKING SHIFT AND 4WD CABLES (AJ) ..	7-45		
USING BIODIESEL (AK)	7-46		
ADJUSTING BELT TENSION (AL)	7-46		
WASHING (AM)	7-47		
PROTECTING PLASTIC AND PAINTED SURFACE (AO)	7-48		
CHECKING HYDRAULIC OIL (AP)	7-48		
CLEANING AIR CONDITIONER CON- DENSER (AQ)	7-49		
CHECKING REFRIGERANT (AR)	7-49		
AIR CONDITIONER MAINTENANCE (AP) ..	7-49		



MAINTENANCE CHECK LIST

DAILY CHECK CHART

ITEM	SERVICE SCHEDULE	MAINTENANCE CODES
	SERVICE REQUIRED	
Engine Cooling System	Clean debris from radiator, screen and grills. Check coolant level in the reservoir tank.	O, P, Q
Seat Belt	Check the condition of seat belt and mounting hardware.	
Tires	Check for wear, damaged tires and air pressure. Check wheel hub nuts are tightened.	
Parking Brake condition	Check operation and adjust if required.	AA
Brake condition	Check operation and adjust if required.	
Clean Pedals	Clean brake pedals, travel control pedal, and footrest area.	Y
General Items	Check for loose or broken parts, instrument operation, oil leaks and damaged or missing signs (decals).	AE, AF, AG, AH

※ For detailed information about maintenance codes, refer to the corresponding section in each chapter.



MAINTENANCE INTERVAL TABLE

※ ◎: Just once initially, ○: In every interval

NO	INTERVAL CHECK ITEM		RUN HOUR								RUN AGE		MAINTENANCE CODES		
			10	50	100	200	250	300	400	800	1000	1YEAR		2YEAR	
1	Engine oil and filter	Replace		◎			○								F
2	Fuel filter	Replace				○									L
3	Fuel line and hose connection	Check	◎		○										M
4	Fuel tank and its filler cap	Check			○										L, M
5	Air cleaner filter	Check			○										H
		Replace									○				
6	Air intake hose connection and filter body anti-dust valve	Check	◎		○										I
7	Valve clearance	Check									○				
8	Injection nozzle	Check									○				N
9	Spark arrester	Check				○									R
10	Coolant	Replace											○		P
11	Cooling system (radiator grill, coolant hose, cooling fan)	Check	◎			○									O, P, Q1, Q2
12	CVT belt	Replace						○							J
13	CVT pulley and system	Check								○					J, K
14	Gearbox and front/rear axle oil	Check	◎			○									S, T, U
		Replace								○					



※ ◎: Just once initially, ○: In every interval

NO	CHECK ITEM	INTERVAL	RUN HOUR								RUN AGE		MAINTENANCE CODES		
			10	50	100	200	250	300	400	800	1000	1YEAR		2YEAR	
15	Brake fluid level	Check	◎		○										X
16	Front/rear wheel and parking brake pads	Check				○									AA, AC
17	Suspension mounting bushing play and mounting rubber	Check				○									AC
18	Leakage from shock absorber	Check							○						AC
19	Wheel hub bearing clearance	Check								○					
20	Wheel hub bolt tightness	Check	◎			○									
21	Other bolt tightness	Check				○									
22	Battery	Check				○									AD
23	Steering rack and pinion, ball joint	Check							○						W
24	Drive shaft and CV boots	Check		○											
25	ROPS and safety belt	Check	◎			○									
26	Greasing drive shaft	Check			○										D
27	A/C Filter	Replace	Recommend exchange based on every 10,000 km or 6 months, whichever comes first										AT		

⊕ IMPORTANT

- ◎ must be done after the first 10 or 50 hours of operation.
- Engine should be operated, used and maintained in accordance with the owner's manual in order to maintain the emissions performance of the engine.

LUBRICANTS

To prevent serious equipment damage, use only genuine **KIOTI** fluids, oils and greases, or equivalents.

NO.	ITEM	Capacity [U.S. gal. (L)]	LUBRICANTS
1	Fuel	9.8 (37.0)	Diesel fuel
2	Coolant	1.45 (5.5)	Antifreezing solution (Ethylene glycol) + Pure water (50:50)
3	Engine oil	0.85 (3.2)	Engine Oil : API CH Grade Above Oil Viscosity : SAE 10W30, 10W40, 15W40
4	Gear Box Oil	0.24 (0.9)	Daedong : UTF 55 Shell : Donax-TD, Exxonmobil : Mobilfluid 424 Exxon Hydraul 560 BP : Tractran UTH
5	Front differential case oil	0.16 (0.6)	
6	Rear differential case oil	0.2 (0.8)	
7	Grease ● Rear axle drive shaft ● Front wheel hubstrut	Small amount	NLGI grade NO.2 or equivalent
8	Brake Fluid	-	DOT3

**⚠ WARNING**

- ***Check the oil level regularly. Correct the oil level, if needed, before operating.***
- ***Always check and add oil with the vehicle on a flat, level surface.***
- ***Do not deliberate tampering with or misuse of the engine emissions control system.***
- ***Engine should be promptly rectified any incorrect operation, use or maintenance for the emissions control system.***
- ***Use the following fuel to maintain the performance of the emissions control system. Fuel with Sulphur content not greater than 10mg/kg, cetane number not less than 45 and FAME content not greater than 8% v/v shall be used. (EU model)***



DAILY INSPECTION ACCESS FOR SERVICE

This vehicle is designed so that it is easy to access the inspection points for service. Most of regular services can be performed by opening the inspection shield under the seat, seat and cargo bed.

OPENING INSPECTION SHIELD (A)

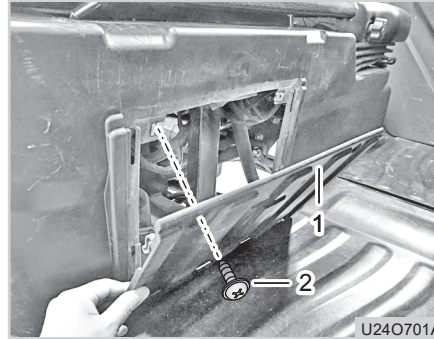

(1) Inspection Shield

To check the engine oil, unscrew the mounting bolts of the inspection shield under the seat and then open the inspection shield.

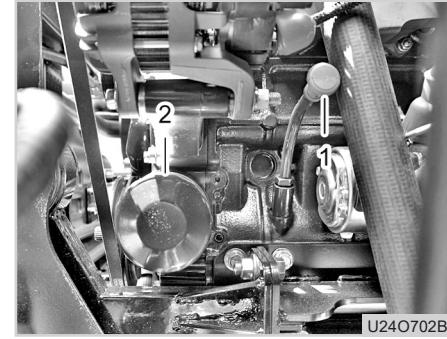

(1) Engine Oil Dipstick (2) Oil Filter

It is possible to check the engine oil dipstick, oil filter, fan belt tension, start motor power connection, etc. after opening the inspection shield.

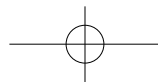



OPENING SEAT CUSHION (B)

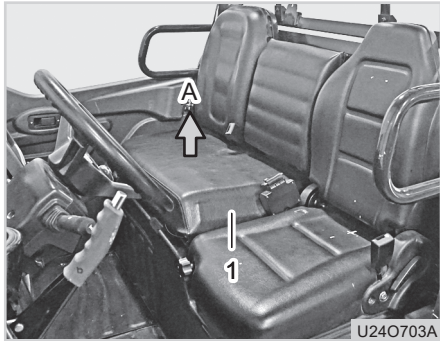

(1) Passenger's Seat (2) Remove

When disassembling the seat, disconnect the passenger's seat, remove the seat bottom plate, and then inspect the engine compartment.

Most of the engine services, including engine oil change and head cover repair, can be performed by opening the seat cushion.



RAISING CARGO BED (C)

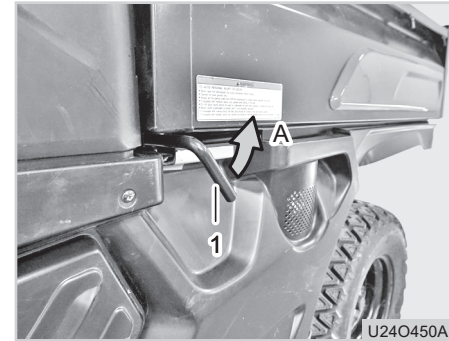

(1) Dumping Lever
(A) Pull Up

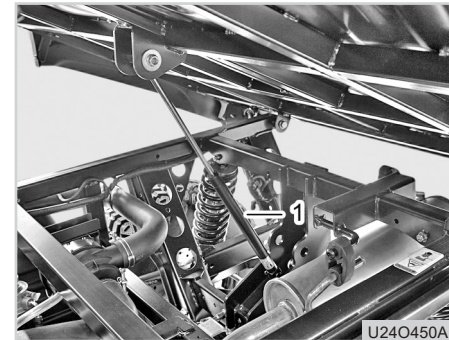

(1) Gas Spring Kit



It is possible to check the gearbox oil, CVT, muffler, air filter, fuel strainer, parking brake pad for wear and play, shift lever cable and differential lock cable play by raising the cargo bed.

Also, most of the service items can be inspected by lifting the cargo bed and removing the seat cushion.

CAUTION

- **Be sure to lock the dumping lever and remote hydraulic lever with lever lock bracket while driving the vehicle.**

APPLYING GREASE (D)

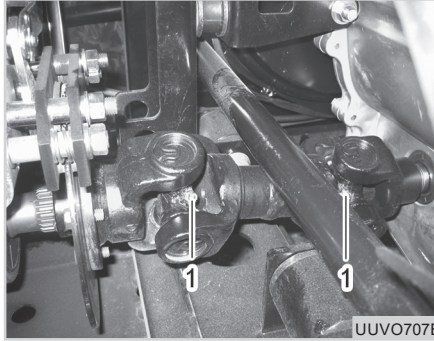

(1) Grease Fitting (Rear axle drive shaft)

There are twenty-one greasing points. Two of them are located on both ends of the universal joint which connects the gearbox and rear axle. Raise the cargo bed and then apply grease to the greasing points. It is recommended to use NLGI grade No. 2 grease.

The other six are located on the front

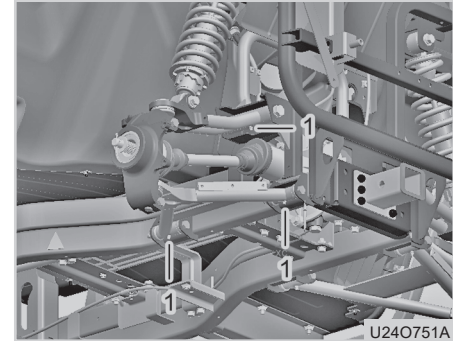

(1) Grease Fitting (Front suspension)

suspension. Remove the front wheels to give grease.



(1) Grease Fitting
(Front axle drive shaft around gear box)

It is located on the spline area of front axle drive shaft around the gear box. Raise up the cargo bed to feed the grease to this fitting.

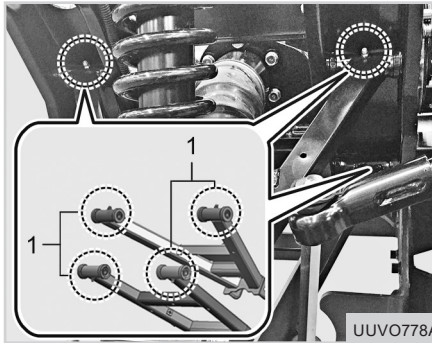

The remaining twelve are located in the rear suspension section. Remove the rear wheels to add grease.

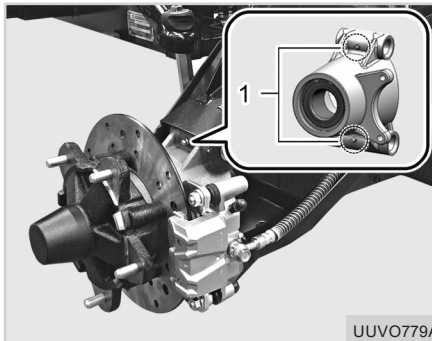

(1) Grease fitting



CHECKING ENGINE OIL LEVEL (E)

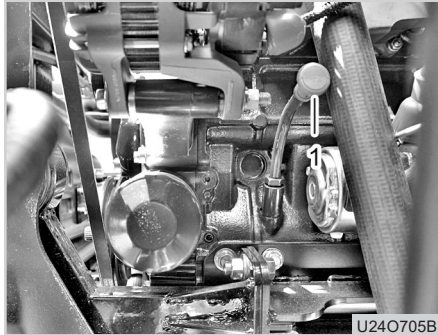

(1) Oil Dipstick

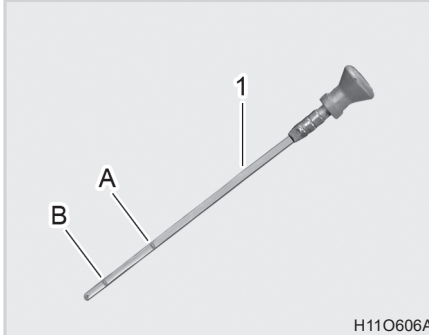

(1) Oil Dipstick
(A) MAX Limit

(B) MIN Limit

1. Park the vehicle on level ground and apply the parking brake firmly.
2. Stop the engine and wait at least for 5 minutes.
3. Unscrew the mounting bolts of the inspection shield from under the seat cushion.
4. Pull out the engine oil dipstick and wipe it clean.
5. Insert the dipstick into the end, and then pull it out to check the engine oil level.

6. If the oil level is below the MIN limit, add some oil. If the oil level is above the MAX limit, drain some oil through the drain plug.
7. Insert the dipstick to its end and close the inspection shield.

⊕ IMPORTANT

- The engine oil should be checked regularly. Driving without sufficient engine oil can lead to severe engine damage.
- It is recommended to inspect the engine when it is cold before starting it.
- The oil level should always be between the MAX and MIN limits.
- Be sure to stop the engine to prevent an accident when checking the engine oil or re-fueling.



CHANGING ENGINE OIL AND FILTER (F)

1. Warm up the engine oil by operating the engine for approx. 10 minutes or driving the vehicle.
2. Park the vehicle on level ground, stop the engine and apply the parking brake firmly.
3. Remove the inspection shield and seat cushion.



(1) Drain Plug

4. Place a container under the drain plug and remove the drain plug to drain the oil to the container. Be careful as the engine oil may be hot.

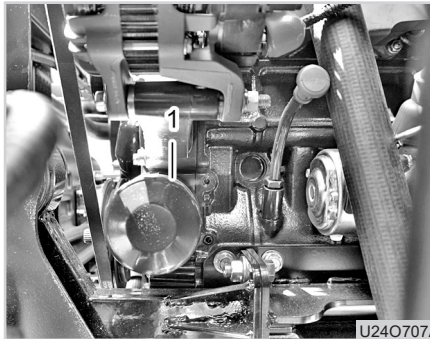

(1) Oil Filter

5. Remove the oil filter through the inspection shield and discard it.
6. Apply a thin film of oil to the rubber O-ring of a new oil filter. Then, install it by tightening it firmly to its end by hand.
7. Install the drain plug firmly.



(1) Filler Cap

8. Open the filler cap and slowly add new oil.
9. The engine oil capacity for this vehicle is as follow.

Oil Capacity
0.85 U.S.gal. (3.2 L)

10. Install the filler cap.
11. Start the engine and run it at a low speed without load. Then, check if any oil has leaked.



12. Stop the engine and wait for approx. 5 minutes. Then, check the oil level and add oil as necessary.
13. Install the seat cushion and inspection shield to their original positions.

⊕ IMPORTANT

- Do not overfill the oil. Overfilled oil applies excessive stress to the crankshaft, leading to serious malfunction.
- Trying to drain the oil while it is hot may cause serious skin burn.

DUST VALVE (G)

It is necessary to remove dust from the anti-dust valve of the air filter frequently.

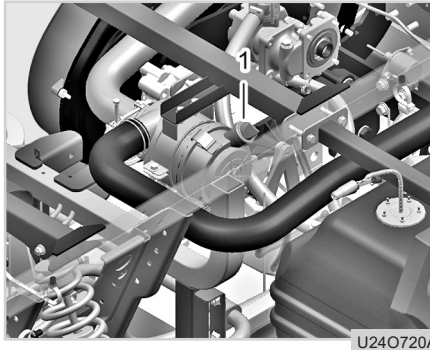

(1) Anti-dust Valve

4. Check if the anti-dust valve is torn or damaged and replace it as necessary.

⊕ IMPORTANT

- Do not operate the engine without the anti-dust valve or air filter. The engine can be damaged.

1. Park the vehicle on level ground and apply the parking brake firmly.
2. Stop the engine and raise the cargo bed. (In case the hydraulic dumping kit is installed, raise the car go bed before stopping the engine.)
3. Press the corner of the anti-dust valve to remove foreign materials accumulated inside as shown in the figure.



REPLACING AIR FILTER (H)

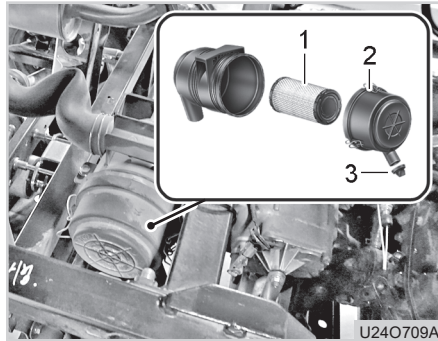

(1) Filter (2) Cap
(3) Evacuator Valve

1. Park the vehicle on level ground and apply the parking brake firmly.
2. Stop the engine and raise the cargo bed.
3. Open the cover of the air filter canister to replace the filter.
4. Make sure to fit the filter to the center of the canister.
5. Install the canister cover after checking that the anti-dust valve is facing downward without any gap.

CHECKING AIR HOSE AND CLAMP(I)

If there is a tiny gap caused by a loose connecting clamp on the air hose, air without passing through the air filter could enter the system for a long period of time, resulting in shortening the service life of the engine. Carry out the check according to the service intervals in this manual as follows.



(1) Clamp 1 (2) Clamp 2

1. Park the vehicle on level ground and apply the parking brake firmly.
2. Stop the engine, remove the seat cushion and raise the cargo bed. (In case the hydraulic dumping kit is installed, raise the cargo bed before stopping the engine.)
3. Check if the clamps (1 and 2) are loose. If so, tighten them.
4. Check if there is tiny cracks or flaws on the rubber hose and replace it if necessary.



CHECKING CVT BELT (J)

It is not easy to inspect the CVT on your own. It is recommended to have it inspected by your **KIOTI Dealer**.

1. Park the vehicle on level ground and apply the parking brake firmly.



(1) Side cover

U45O706B

2. Stop the engine, remove the seat cushion and remove the side cover on the left of the vehicle.



U24O712A

(1) Battery

3. Remove the battery.

WARNING

- **You can get burnt by touching hot parts, such as the muffler. Wait until hot parts are cooled down after stopping the engine.**



U45O707B

(1) Heat shield cover 1
(2) Heat shield cover 2

4. Remove the heat shield covers (1 and 2).

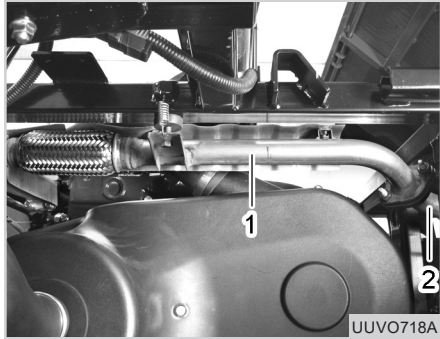

(1) Exhaust Pipe (2) Muffler

5. Remove the exhaust pipe, but leave the muffler in place.

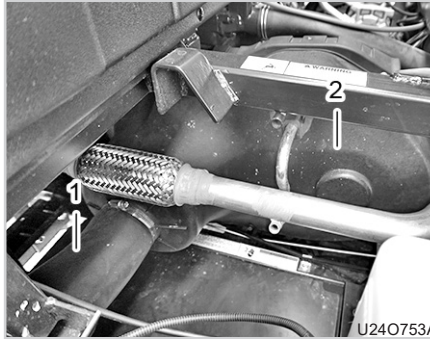

(1) Air Hose (2) CVT Cover

6. Remove the air hoses (1) from the CVT cover.
7. Remove the CVT cover (2).

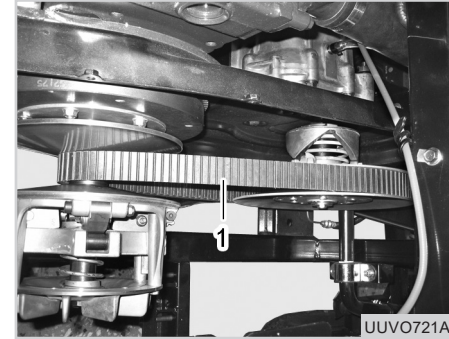

(1) CVT Belt

8. Replace it with a new one if it has been used for more than 300 hours. For replacement, contact your **KIO-TI Dealer**.



9. If foreign materials are caught in the components such as the CVT belt or CVT pulley or there is dust inside the CVT cover, clean thoroughly with vacuum cleaner and reassemble them.

⊕ IMPORTANT

- **Never apply grease, oil, or similar fluids on the surface of the belt and pulley.**

CHECKING CVT DRIVEN PULLEY CLUTCH BUTTONS (K)

1. Remove the relevant parts such as the CVT cover by following the same procedure as for the CVT belt service (see "Checking CVT belt").

4. If foreign materials are caught in the components such as the CVT belt or CVT pulley or there is dust inside the CVT cover, clean thoroughly with vacuum cleaner and reassemble them.

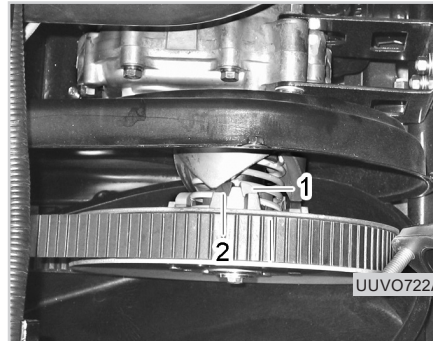

(1) Clutch Button 1 (2) Clutch Button 2

2. Check the CVT driven pulley clutch buttons (1 and 2) for wear.
3. If they should need replacement due to excessive wear, contact **KIOTI Dealer**.



CHECKING FUEL FILTER(L)

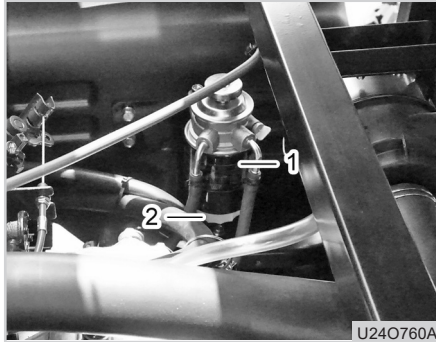

(1) Fuel Filter

(2) Drain Plug

NOTE

- It is recommended to start servicing after filling the fuel tank to its top for easy bleeding, as it might be needed to bleed the fuel line after servicing the fuel system.

1. Park the vehicle on level ground and apply the parking brake firmly.
2. Stop the engine and raise the cargo bed, making sure support is latched. (In case the hydraulic dumping kit is installed, raise the car go bed before stopping the engine)
3. Water and dust in fuel are accumulated in the filter. Remove the plug from the bottom of the fuel filter to drain any impurities.
4. Tighten the filter with a hand (Not a tool) after drainage.
6. Start the engine and check for fuel leakage.
7. If engine cannot be started, this could be due to air in the fuel line. Bleed the fuel line, referring to "Bleeding fuel line".

REPLACING FUEL FILTER

1. Wipe the surface of the fuel filter clean.
2. Unscrew the plug on the bottom of the fuel filter to drain fuel.
3. Remove the fuel filter.
4. Remove foreign materials, such as dirt, thoroughly and replace the fuel filter with a new one.



BLEEDING FUEL LINE (M)

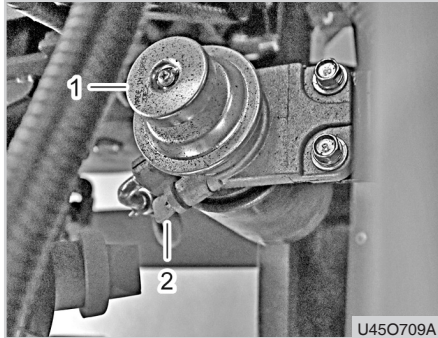

(1) Pump

(2) Air Plug

1. Make sure that the amount of fuel in the tank is sufficient.
2. If air is introduced into the fuel system line, it becomes hard to start the engine. In this case, unscrew the bleeding bolt (2) and press down the priming pump (1) on top of the fuel filter several times.
3. Fuel with bubbles starts to flow out through the gap of the unscrewed bleeding bolt. When the flowing fuel

no longer has bubbles, tighten the bleeding bolt and try starting the engine.

CAUTION

- **Do not operate the start motor for more than 5 seconds continuously. Instead, operate it for several times within 5 seconds each time.**

NOTE

- This bleeding procedure can be skipped if filling the fuel filter with fuel before installation.

IMPORTANT

To protect the catalyst filter, keep the followings:

- **Make sure to use only genuine fuel.**
- **Keep the engine oil replacement schedule.**
- **Check the engine oil level frequently to keep it to the specified level.**
- **Avoid any unnecessary engine idling.**
- **Never stop the engine during driving.**
- **Never place the shift lever in the neutral position when driving downhill.**
- **Do not use any engine oil additive or fuel additive.**
- **Avoid driving with any warning lamp illuminated.**
- **Do not allow any flammable materials, such as dry grass and paper, to come near the catalyst filter while parked.**

**⚠ CAUTION**

- **Never bleed the fuel system while the engine is hot.**

⊕ IMPORTANT

- **After bleeding, fuel without air bubbles is filtered by the fuel filter and is transferred to the fuel injection pump. Maintain the proper fuel level in the fuel tank before the fuel tank becomes empty. If all fuel is completely consumed in a Diesel engine, fuel should be added to the fuel tank and then the fuel system should be bled.**

📖 NOTE

- **If the engine cannot be started even after bleeding the fuel system, contact your local Dealer.**

CHECKING INJECTION NOZZLE AND FUEL INJECTION PUMP (N)

The injection nozzle and injection pump can be inspected only by a qualified service personnel. For detailed information, contact your **KIOTI Dealer**.

⊕ IMPORTANT

- **Modifying sealed parts in the fuel system, such as the flow limit bolt and engine rpm limit bolt, is strictly prohibited by the emission regulations. If such regulations are not followed, it will not be covered by warrant and will void any warranty.**

CLEANING RADIATOR CORE (O)

1. Park the vehicle on level ground and apply the parking brake firmly.
2. Stop the engine, open the hood and support it.



(1) *Brush Guard*

3. Remove the three grilles from the brush guard.

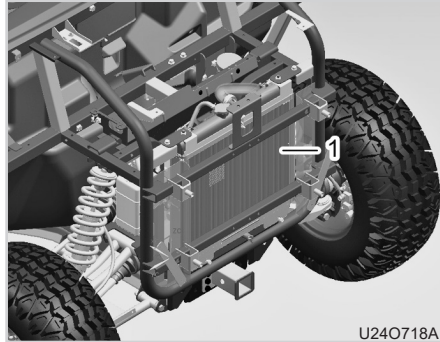

U24O718A

(1) Radiator

4. Spray compressed air or water to the radiator from its inside toward outside to remove any foreign materials stuck in the radiator core.

! WARNING

- **Do not remove the radiator cap while the engine is hot. You can get burnt by hot steam. Make sure to remove it after the engine and radiator have cooled down enough.**

+ IMPORTANT

- **Driving with the radiator core clogged by foreign materials can deteriorate heat radiation performance, resulting in the overheated engine.**
- **If the distorted or clogged area of the radiator core is over 30% of its total area, it is recommended to replace it with a new one. For replacement, contact your KIOTI Dealer.**

CHECKING COOLANT IN AUXILIARY COOLANT TANK (P)

When the coolant in the radiator expands by heat, it overflows into the auxiliary coolant tank. On the other hand, when the coolant temperature in the radiator decreases, the radiator is depressurized and the coolant in the auxiliary coolant tank flows to the radiator to keep the amount of the coolant in the radiator consistent. Perform the following steps to check the auxiliary coolant tank.

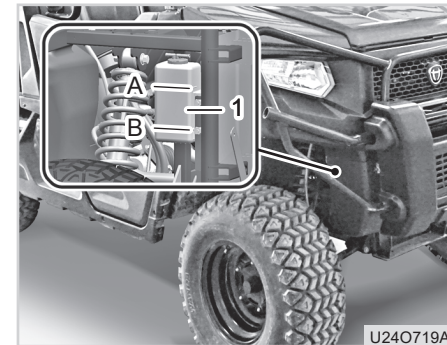

U24O719A

(1) Auxiliary coolant tank
(A) MAX Limit

(B) MIN Limit



1. Park the vehicle on level ground and apply the parking brake firmly.
2. Check the coolant level through the sight glass of the auxiliary coolant tank. It is located on the inner side of the right front wheels well.
3. If the engine is hot, the coolant level may be higher than normal. In this case, run the engine at a low speed without a load until the coolant in the radiator is cooled down and the coolant in the auxiliary coolant tank flows to the radiator.
4. When the coolant is cooled down sufficiently, add water an anti-freeze mix to the auxiliary coolant tank so that the coolant level is between the MAX and MIN limits.
5. If the coolant level decreases continuously, have your vehicle inspected by your **KIOTI** Dealer.

⊕ IMPORTANT

- **If you have to keep adding water to the auxiliary coolant tank, or the coolant becomes diluted the radiator can burst in cold weather. Contact your KIOTI Dealer to find the cause and have fixed.**

⚠ WARNING

- ***Do not remove the radiator cap while the engine is hot. You can get burnt by hot steam. Make sure to remove it after the engine and radiator have cooled down enough.***

1. Park the vehicle on level ground and apply the parking brake firmly.
2. Stop the engine and let the engine cooled down sufficiently.
3. Open the hood.



(1) Radiator Cap



4. After confirming the radiator cap is not hot, unscrew it counterclockwise slowly pressing it down. Unscrew it in several steps to remove any inner pressure safely.
5. Remove the cap after the inner pressure is removed.



(1) Brush Guard

6. Remove the lowest grille from the brush guard.



(1) Coolant drain plug of radiator

7. Place a container with a wide opening under the vehicle and open the drain plug to drain the coolant.

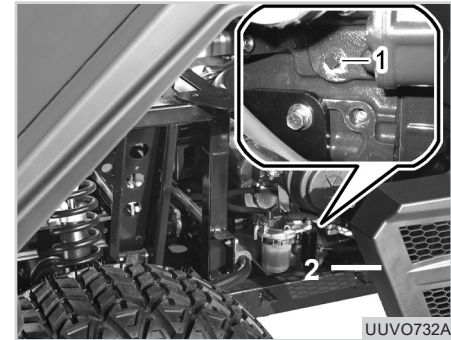

(1) Engine Coolant Drain Plug
(2) Engine Oil Filter

8. Now drain the coolant from the engine by removing the engine coolant drain plug.

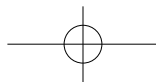

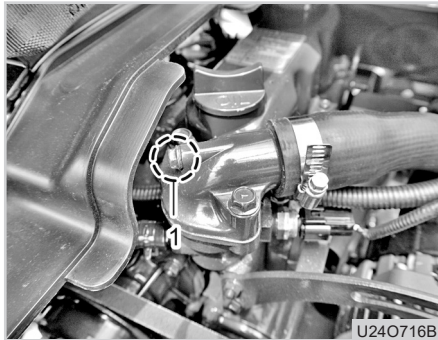

(1) Air Bleeder Bolt

9. Loosen the air bleeder bolt for fast drain.
10. Disconnect the hose from the bottom of the auxiliary coolant tank to drain the coolant in it.
11. Flush the cooling system with clean water 2 to 3 times as necessary until clean water is present.
12. Reconnect the hose to the auxiliary coolant tank.
13. Make sure to install the drain plugs for radiator and engine before filling new coolant.
14. Fill the tank with water and anti-freeze (Ethylene glycol) in ratio of 50:50.
15. Fill slowly the new coolant through radiator filler with bleeding air out from the air bleeder bolt loosened.
16. Make sure to maximize the temperature of the air conditioner controller and add coolant. When temperature is lowered and inserted, the valve is locked and coolant is not allowed into the HVAC. Air bleed the engine at idle for approximately 10 minutes after filling the coolant. (The HVAC is located on the top of the radiator and does not completely air bleed with natural injection; air bleed must be performed to the HVAC using the engine water pump.)
17. Squeeze the coolant rubber hoses several time before tightening the bleeder bolt to make sure no air left

in hoses.

18. Make sure every plugs and caps for cooling by system is inplaced firmly.
19. Test run the engine to find any leakage.
20. The coolant mixture ratio may differ by local climate. Therefore, contact your **KIOTI** Dealer for the correct mixture ratio.

Coolant Capacity

1.45 U.S Gal. (5.5 L)
Water+Ethylene glycol (50:50)

21. If a different type of anti-freeze is to be used, fill the cooling system with clean water, run the engine for approx. 5 minutes and drain the water. Repeat this 2 to 3 times before adding new anti-freeze.

BLEEDING AIR IN COOLANT(Q2)

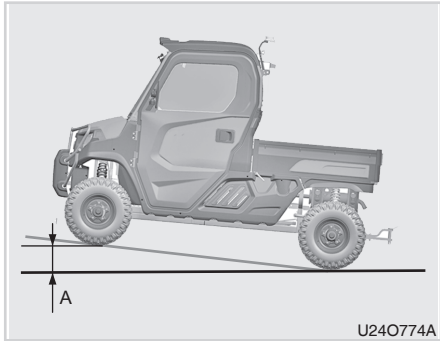

U24O774A

(A) 300mm

1. Raise the front tires to at least 300mm off the ground.

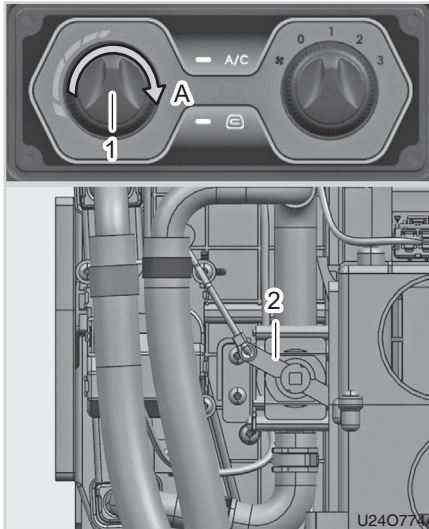

U24O774A

- (1) Heater temperature control dial
- (2) Heater valve
- (A) Turn the heater temperature to maximum

2. Raise the heater temperature to maximum. Visually check that the HAVC heater valve is working.

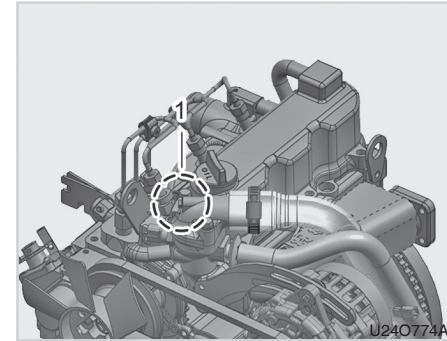

U24O774A

(1) Air bleed bolt

3. Loosen the engine air bleed bolt completely, inject coolant through the radiator, check that the coolant flows through the bolt hole, and then close the air bleed bolt.
4. After starting the engine, keep the RPM above 2000 and bleed the air until the coolant capacity is 5.5L.

 **NOTE**

1. After 10 minutes of starting the engine (2000RPM), check if the coolant temperature in the instrument panel is maintained at 3 levels.
2. Check if the hot air is coming out of the vent.

**CHECKING SPARK ARREST-
ER OF EXHAUST PIPE (IF
EQUIPPED) (R)**

1. Park the vehicle on level ground and apply the parking brake firmly.
2. Stop the engine and let the engine cooled down sufficiently.
3. Loosen the fixing bolt and then remove the spark arrester.
4. Apply WD-40 or equivalent to the inner side and blow any residual with compressed air. Do not blow with compressed air too closely, or the filter can be damaged.
5. If the filter is damaged, replace the spark arrester with a new one.

 **WARNING**

- *You can get burnt by touching hot parts, such as the muffler. Wait until hot parts have cooled down after stopping the engine.*

**CHECKING AND CHANGING
GEARBOX OIL (S)**

1. Park the vehicle on level ground and apply the parking brake firmly.
2. Stop the engine and let the engine cool down sufficiently.
3. Raise the cargo bed and support it with the support rod.



(1) Filler Plug

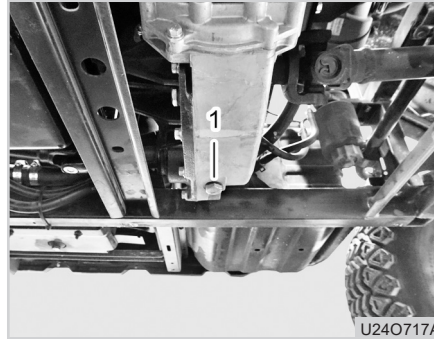

(1) Drain Plug

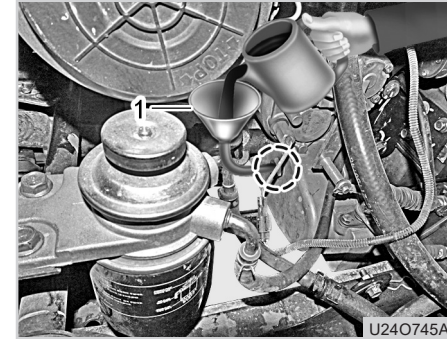

(1) Funnel

4. Clean around filler plug, then remove the filler plug.
5. Check that the gearbox surface is not hot. Then, check the oil level and condition with a finger bent slightly. If you cannot reach the oil, it means the oil level is low. Add oil as needed to fill.
6. If the color or viscosity of the oil is not normal or it is at the oil change interval, change the oil.

7. To change oil, place a container with wide opening under the drain plug. Then, remove the drain plug.
8. After draining all the oil, install the drain plug firmly.
9. When adding new oil, add it through a long hose into the fill plug location. Fill until oil starts to spill out of filler plug hole.

Oil Capacity
0.2 U.S Gal. (0.9 L)

10. Check the oil level by performing the step 5 in the previous page. If the oil level is normal, install the filler plug.
11. Wipe the gearbox and is surrounding with a rag thoroughly.
12. Test drive the vehicle for 5 to 10 minutes to check for leakage.

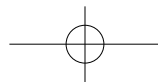

**⚠ WARNING**

- *You can get burnt badly by hot oil. Make sure to work on it after it is sufficiently cooled down.*

CHECKING AND CHANGING FRONT AXLE OIL (T)

1. Park the vehicle on level ground and apply the parking brake firmly.
2. Stop the engine and let the engine cool down sufficiently.
3. Raise the hood and support it with the support rod



(1) Filler Plug

4. Clean around filler plug, then remove the filler plug.
5. Check that the differential case surface is not hot. Then, check the oil level and condition with a finger bent slightly. If you cannot reach the oil, it means the oil level is low. Add oil as needed.
6. If the color or viscosity of the oil is not normal or it is at the oil change interval, change the oil.



(1) Drain Plug

7. To change oil, place a container with wide opening under the drain plug. Then, remove the drain plug.

8. After draining all the oil, install the drain plug firmly.



(1) Funnel

9. When adding new oil, add it through a long hose into the filler plug location. Fill until oil starts to spill out of filler plug hole.

Oil Capacity
0.16 U.S Gal. (0.6 L)

10. Check the oil level by performing the step 5 in the previous page. If the oil level is normal, install the filler plug.

11. Wipe the differential case and its surrounding with a rag thoroughly.
12. Test drive the vehicle for 5 to 10 minutes to check for leakage.

⚠ WARNING

- *You can get burnt badly by hot oil. Make sure to work on it after it is sufficiently cooled down.*



CHECKING AND CHANGING REAR AXLE OIL (U)

1. Park the vehicle on level ground and apply the parking brake firmly.
2. Stop the engine and let the engine cooled down sufficiently.



(1) Filler Plug

3. Clean around filler plug, then remove the filler plug.
4. Check that the differential case surface is not hot. Then, check the oil level and condition with a finger bent slightly. If you cannot reach the oil, it means the oil level is low. Add some oil.

5. If the color or viscosity of the oil is not normal or it is at the oil change interval, change the oil.

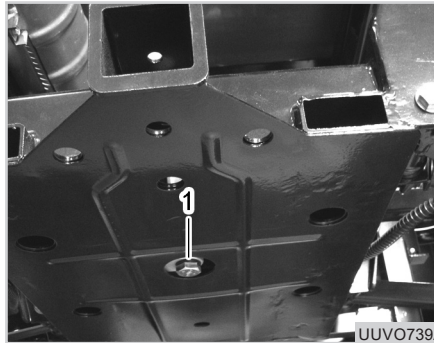

(1) Drain Plug

6. To change oil, place a container with wide opening under the drain plug. Then, remove the drain plug.
7. After draining all the oil, install the drain plug firmly.



(1) Funnel

8. When adding new oil, add it through a long hose into the fill plug location. Fill until oil starts to spill out of filler plug hole.

Oil Capacity
0.21 U.S Gal. (0.8 L)

9. Check the oil level by performing the step 4 in the previous page. If the oil level is normal, install the filler plug.



10. Wipe the differential case and its surrounding with a rag thoroughly.
11. Test drive the vehicle for 5 to 10 minutes to check for leakage.

⚠ WARNING

- **You can get burnt badly by hot oil. Make sure to work on it after it is sufficiently cooled down.**

CHECKING DRIVE SHAFT AND CV BOOTS (V)

1. Park the vehicle on level ground and apply the parking brake firmly.
2. Stop the engine.



(1) CV Boots (Front Wheel)

3. Check if the CV boots of the drive shaft for the front wheels are torn or have a sign of leakage.

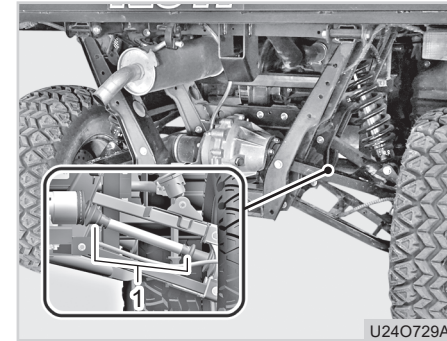

(1) CV Boots (Rear Wheel)

4. Check if the CV boots of the drive shaft for the rear wheels are torn or have a sign of leakage.
5. If the CV boots should be replaced, contact your **KIOTI** Dealer.

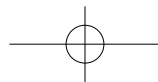



CHECKING STEERING RACK BOOTS AND BALL JOINT (W)

1. Park the vehicle on level ground and apply the parking brake firmly.
2. Stop the engine.
3. Open the hood and support it.

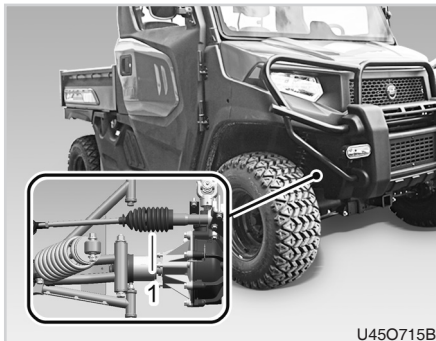

(1) Steering Rack Boot

4. Check the steering rack boots, to see if torn or have a sign of leakage.



(1) Tie Rod End

5. Turn steering wheel fully to the right and inspect the boots of the tie rod end and nut, then turn wheel fully to the left and inspect boot of the tie rod end and nut.
6. If the above components should be replaced, contact your **KIOTI** Dealer.

⊕ IMPORTANT

- The components related to the steering operation directly affect your safety. If a condition of such components is in doubt, contact your KIOTI Dealer immediately.

CHECKING BRAKE FLUID (X)

1. Park the vehicle on level ground and apply the parking brake firmly.
2. Stop the engine, open the hood and support the hood.

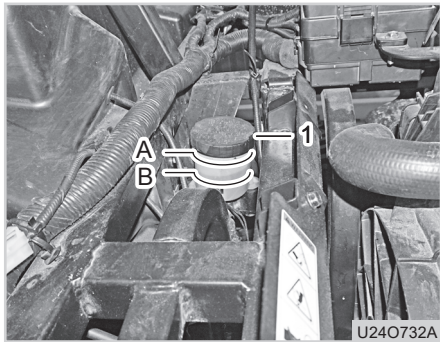

(1) Brake Fluid Tank
(A) MAX Limit (B) MIN Limit

3. Clean the brake fluid tank and its surrounding thoroughly.
4. Check the brake fluid level is between the MAX and MIN limits.
5. If the level is below or close to the MIN limit, fill the tank with the brake fluid to the MAX limit.

Brake Fluid
DOT 3

6. If the brake fluid is severely contaminated or insufficient, contact your **KIOTI Dealer**.

CHECKING BRAKE PEDAL FREE PLAY (Y)

The master cylinder rod of the vehicle is adjusted so that the brake pedal free play is 15 ~ 20 mm (0.59 ~ 0.79 in.) at factory. If the free play of the brake pedal should be adjusted, perform the following steps.

1. Park the vehicle on level ground and apply the parking brake firmly.
2. Stop the engine, open the hood and support the hood.

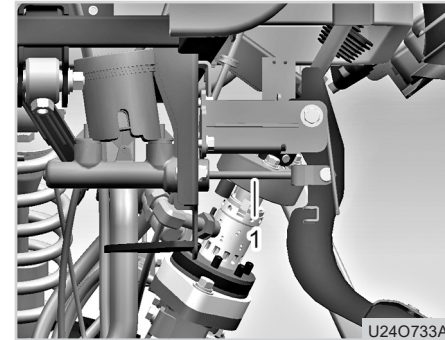

(1) Master Cylinder Rod

3. Measure the free play of the brake pedal. According to the measurement, adjust the length of the master cylinder rod (1).



CHECKING BRAKE PAD (Z)

1. Park the vehicle on level ground and apply the parking brake firmly.



(1) Wheel Nut

2. Unscrew the nuts of the wheel to be checked only 1 turn.
3. Lift the vehicle with a hydraulic jack and then support the vehicle with the safety stand. Then, lower the hydraulic jack so that the vehicle chassis sits on the stand.
4. Unscrew the wheel nuts completely to remove the wheel.

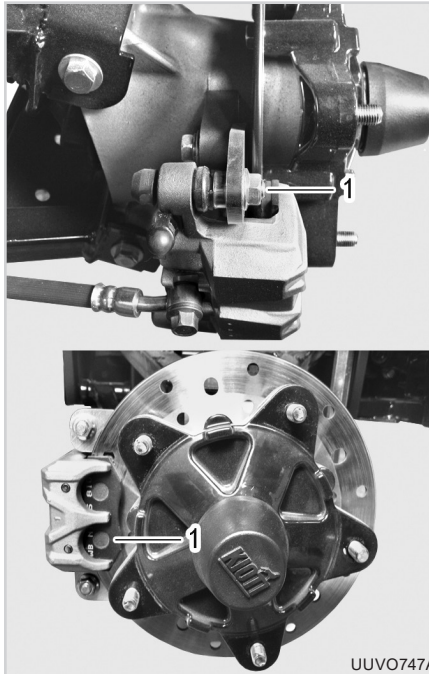

(1) Brake Pad

5. If any of the brake pads on either side of the disc is too thin, close to 0.04 in. (1 mm), both pads for that disc as well as the pads for the wheel on the other side should be replaced.
6. Check the brake pads on the other axle, using the same procedure.
7. Check if the brake disc is abnormally worn.
8. If the brake pads should be replaced with new ones or abnormal wear is found on the disc, contact your **KIOTI Dealer**.
9. When reinstalling the wheel after inspection, tighten the wheel nuts firmly.

WARNING

- ***Driving with loose wheel nuts is very dangerous and can lead to overturn and collision. Make sure that they are firmly tightened.***



CHECKING PARKING BRAKE (AA)

NOTE

- The vehicle should be stopped on a slope (up to 10 degrees) when the parking brake is fully applied. With cargo loaded. When driving the vehicle downhill without depressing the brake pedal, there should be no friction resistance. In order to keep the parking brake in the best condition, check the parking brake with the following procedure.

1. Park the vehicle on level ground and apply the parking brake firmly.
2. Stop the engine, raise the cargo bed and support it with the support rod. (In case the hydraulic dumping kit is installed, raise the cargo bed before stopping the engine)

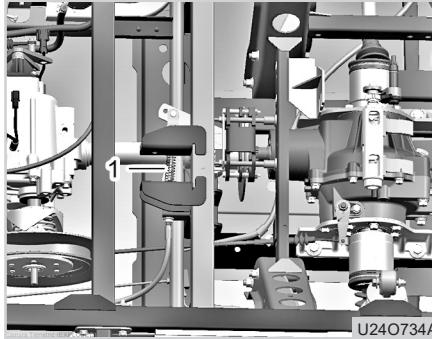

(1) Parking Brake Cable

3. Adjust the length of the parking brake cable. Test the cable according to the procedures described previously and then adjust its length as necessary.

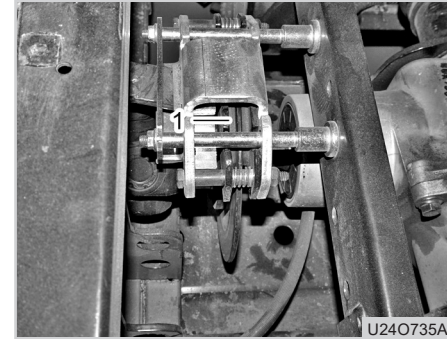

(1) Disc Pad

4. Measure the thickness of the pads on the sides of the parking brake disc. If any of the pads are close to 1 mm (0.04 in.), both pads should be replaced.
5. After replacing the pads, test the parking brake and adjust the cable length accordingly.
6. Check if the parking brake disc is not worn abnormally.



ADJUSTING SUSPENSION (AB)

7. If the parking brake pads should be replaced with new ones or abnormal wear is found on the disc, contact your **KIOTI** Dealer.

The rear suspension equipped on this vehicle is adjustable, to allow for ride quality and weight hauling. To adjust the suspension, perform the following steps:

1. Park the vehicle on level ground and apply the parking brake firmly.



(1) Wheel Nut

2. Unscrew the nuts of one of the rear wheels only 1 turn.
3. Lift the vehicle with a hydraulic jack and then support the vehicle with the safety stand. Then, lower the hydraulic jack so that the vehicle chassis sits on the stand.

4. Unscrew the wheel nuts completely to remove the wheel.

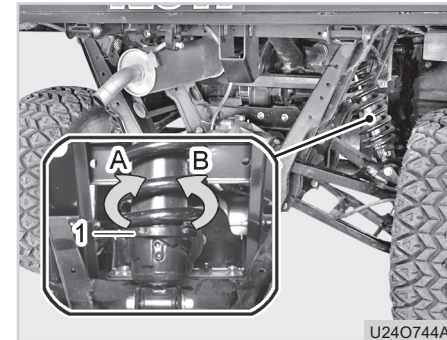

(1) Hole

5. Fit a special service tool to the hole and turn it to adjust the spring load and stroke.



NOTE

- **A direction(soft): suitable for driving mountainous area frequently.**
- **B direction(hard): suitable for transporting cargo frequently.**
- **Special service tool is enclosed in spare tool box.**

6. After adjustment, install the wheel and tighten the wheel nuts firmly.

WARNING

- ***Driving with loose wheel nuts is very dangerous and can lead to overturn and collision. Make sure that the nuts are firmly tightened.***

CHECKING SUSPENSION SHOCK ABSORBER (AC)

If the shock absorber is malfunctioning, your riding comfort can be harmed. In this case, check the shock absorber as follows

1. Park the vehicle on level ground and apply the parking brake firmly.
2. Stop the engine.



U45O717B

(1) Shock Absorber

3. Check for any sign of oil leakage on the shock absorbers for the front and rear wheels and their surrounding.
4. If the shock absorbers should be replaced, contact your distributor/ **KIOTI Dealer.**

BATTERY (SEALED) (AD) INSPECTION

Never open or service the battery and never add electrolyte to the battery. Doing so will not be covered by your warranty. Therefore, when checking the battery, observe the following:

1. Keep the battery and its terminals clean.
2. Connect the battery cables firmly.
3. Make sure the battery vent hole is not clogged.
4. Fit the battery to the vehicle body firmly.



REPLACEMENT

⊕ IMPORTANT

- The battery discharges naturally if the vehicle is stored for an extended period of time. When storing the vehicle for a long period of time, run the engine for approx. 30 minutes monthly to charge the battery. Never leave the vehicle with the engine running.

1. Park the vehicle on level ground and apply the parking brake firmly.
2. Stop the engine.



(1) Side Cover

3. Remove the side cover (LH).

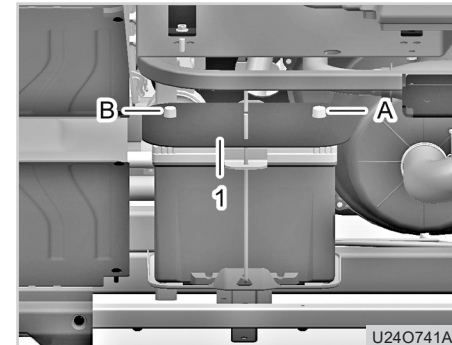

- (1) Battery Cover
 (A) Positive (+) Cable
 (B) Negative (-) Cable

4. Remove the battery cover and disconnect the negative battery cable.
5. Disconnect the positive battery cable.
6. Remove the battery mounting bracket.
7. When connecting cables, connect the positive cable first, and then the negative cable.

⚠ WARNING

- *The battery terminals and cables contains lead. The body accumulates lead which can cause cancer. Make sure to wash your hands after handling these parts.*

⚠ WARNING

- *The battery has acid that can burn your skin.*
- *Make sure to wear protective glasses and gloves.*
- *Wear long sleeves to protect your skin.*
- *If you accidentally inhaled acid, see your doctor immediately.*
- *If acid got in your eyes, flush with water for 15 to 30 minutes and get medical attention immediately.*
- *If acid got on your skin, flush with water immediately and see your doctor.*

⚠ WARNING

- *The battery gas is dangerous enough to cause an explosion.*
- *Do not smoke near the battery.*
- *Do not leave the battery near flame or spark.*
- *Do not touch both terminals of the battery with a metal object simultaneously.*
- *When disconnecting the battery, disconnect the negative battery cable first.*
- *When connecting the battery, connect the positive battery cable first.*

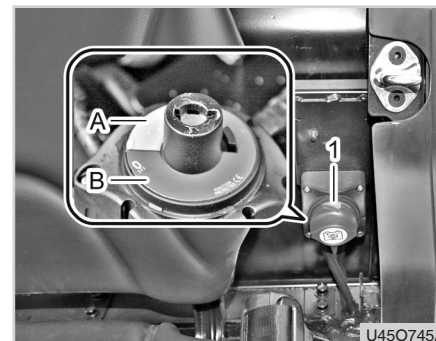
BATTERY SWITCH

(1) Battery Switch

(A) OFF

(B) ON

When the battery switch is set in the "OFF" position, power is blocked. When it is in the "ON" position, power is supplied. Set the switch in the "OFF" position for long-term storage.

 **CAUTION**

- Set the battery switch in the “OFF” position or disconnect the battery cable in approx. 2 minutes after stopping the engine.

CHARGING

Contact the battery dealer for proper charging instruction.

 **CAUTION**

- The charge warning lamp comes on if the charging system is defective. If it comes on while driving, have the system checked or repaired by your local KIOTI Dealer.
- Keep the battery fully charged. If the battery fluid concentration is too low during the winter season, the battery may be frozen.
- Do not start the engine when the battery is frozen. Try to warm it up first.
- If the battery is not securely installed, the battery case and electrolytes could be damaged by vibration. To prevent the battery acid from contacting the terminals, apply grease around the battery terminals and connections.

 **CAUTION**

- Never check the charge status of the battery by placing a metal object across the posts. Use a voltmeter or hydrometer.

DIRECTION FOR STORAGE

1. When storing the UTV for a long period, remove the battery from UTV, store in a dry place out of direct sunlight.
2. The battery self-discharges while it is stored.

Recharge it once every three months in hot seasons and once every six months in cold seasons.



REPLACING HEADLAMP BULB (AE)

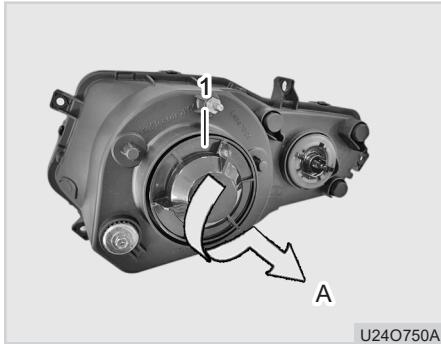

(1) Cover
(A) Pull Out

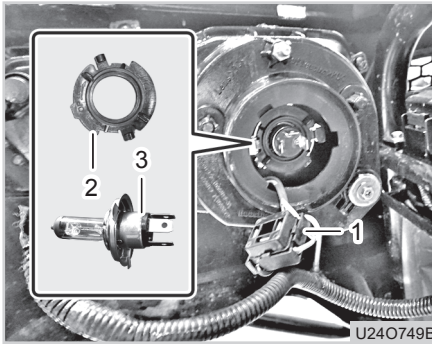

(1) Connector (2) Plate
(3) Bulb

1. Park the vehicle on level ground and apply the parking brake firmly.
2. Stop the engine, open the hood and support the hood.
3. Remove the cover.

No.	Bulb	Capacity
1	Headlamp	HS1 12V 35W/35W
2A	Rear lamp (US)	12V 21W/5W
		21W
2B	Rear lamp (EU, AU)	12V 21W/10W
		12V 21W

4. Remove the connector (1), remove the fixing plate (2), and pull out the socket to remove the bulb (3).
5. When installing a new bulb, be careful not to touch its glass. Durability of a bulb can be deteriorated.
6. Reassemble in the reverse order of disassembly.

CHECKING AND REPLACING FUSE (AF)

1. Park the vehicle on level ground and apply the parking brake firmly.
2. Stop the engine, open the hood and support the hood.

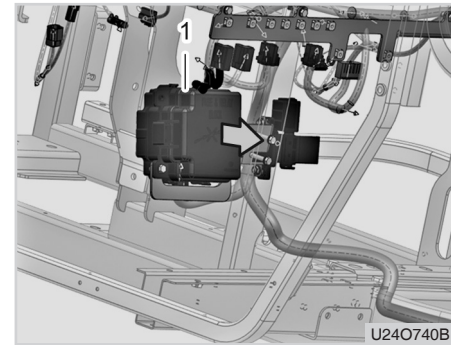

(1) Fuse Box

3. Open the fuse box cover. There are spare fuses and fuse tongs in the center of the box.

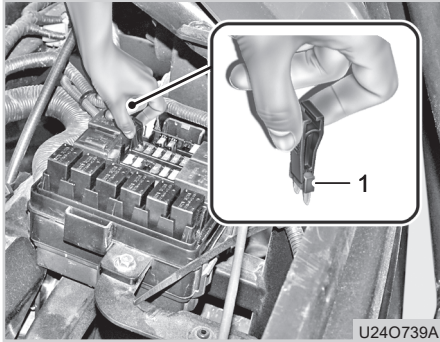

(1) Fuse Tong

- 4. Check or replace the fuse with the fuse tongs.
- 5. If fuses are blown repeatedly, contact your **KIOTI** Dealer.

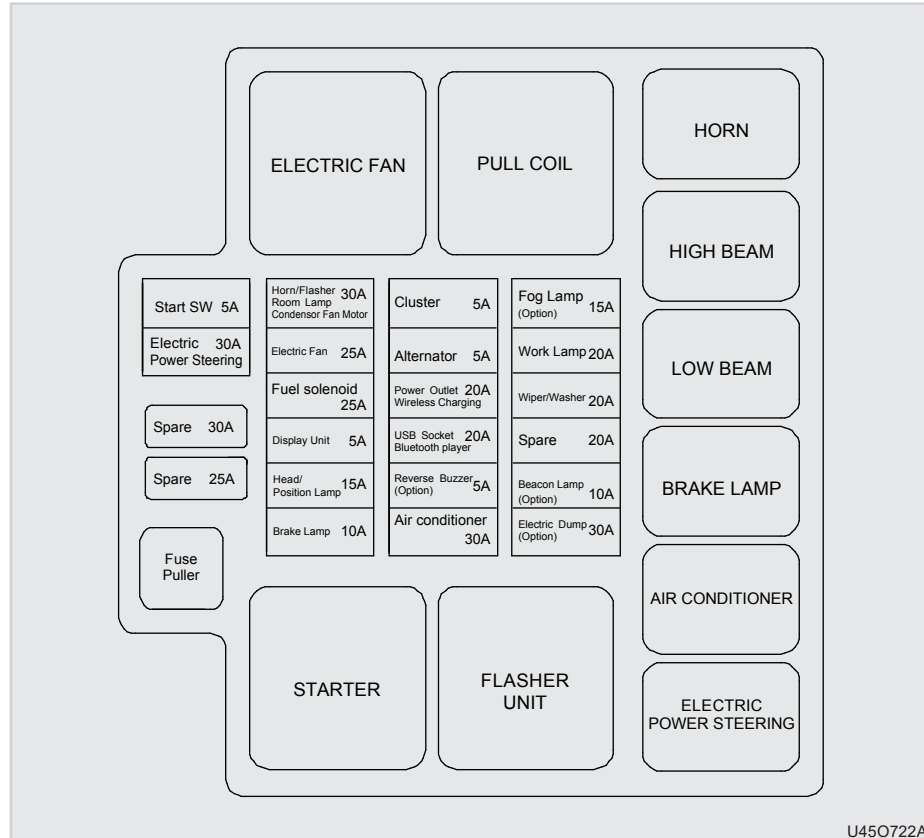

U45O722A



MAIN FUSE (SLOW-BLOW FUSE) (AG)

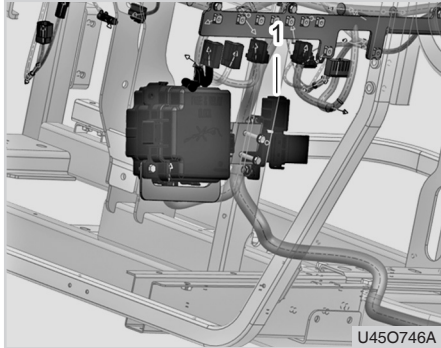

(1) Slow-blow Fuse

If the start motor and all electrical devices do not operate at all when turning the key switch to the "START" position, the first thing to inspect is the main fuse.

1. Remove the engine inspection shield.
2. Check if the yellow slow blow fuse installed to the positive start motor cable is blown.
3. If this fuse is repeatedly blown, contact your **KIOTI Dealer**.

ALIGNING WHEEL AND CHECKING WHEEL NUT (AH)

1. Park the vehicle on level ground and apply the parking brake firmly.



(1) Wheel Nut

2. Unscrew the nuts on the wheel to be replaced for only 1 turn.
3. Lift the vehicle with a hydraulic jack and then support the vehicle with the safety stand. Then, lower the hydraulic jack so that the vehicle chassis sits on the stand.
4. Unscrew the wheel nuts completely to remove the wheel.

5. After reinstalling the wheel after inspection, tighten the wheel nuts firmly.

WARNING

- *Driving with loose wheel nuts is very dangerous and can lead to overturn and collision. Make sure that they are firmly tightened.*

IMPORTANT

- **The tire inflation pressure and wheel nut tightness should be inspected daily.**



CHECKING DIFFERENTIAL LOCK CABLE (AI)

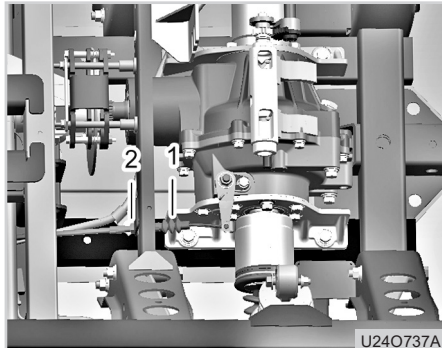

(1) Differential Lock Cable (2) Nut

1. Park the vehicle on level ground and apply the parking brake firmly.
2. Stop the engine, raise the cargo bed and support it with the support rod. (In case the hydraulic dumping kit is installed, raise the cargo bed before stopping the engine)

WARNING

- *You can get burnt by touching hot parts, such as the muffler. Make sure the vehicle is not hot before starting servicing.*

3. Unscrew the nut and adjust the cable length.
4. To check the differential lock operation, lift the rear axle with a jack so that the rear wheels are off the ground.
5. Set the differential lock lever to the "Lock" position and rotate one of the wheels manually. It is normal that the other wheel rotates in the same direction.
6. Set the differential lock lever to the "Unlock" position and rotate one of the wheels manually. It is normal that the other wheel rotates in the opposite direction.

CHECKING SHIFT AND 4WD CABLES (AJ)

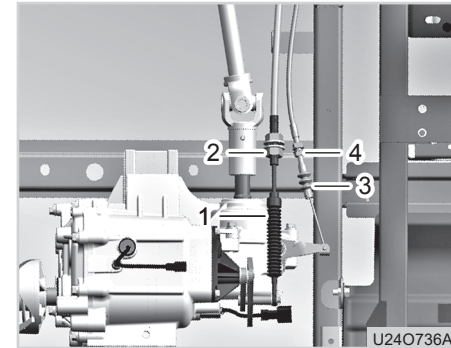

(1) Shift Cable (2) Nut 1
(3) 4WD Cable (4) Nut 2

1. Park the vehicle on level ground and apply the parking brake firmly.
2. Stop the engine, raise the cargo bed and support it.

WARNING

- *You can get burnt by touching hot parts, such as the muffler. Make sure the vehicle is not hot before starting servicing.*



3. Unscrew nut 1 and adjust the length of the shift cable.
4. Unscrew nut 3 and adjust the 4WD cable.
5. To check 4WD operation, lift the front and rear axles completely off the ground and support with jack stands.
6. Start the engine and move the 2WD/4WD lever to "4WD" and "2WD" positions to check rotation of each wheel.

! WARNING

- ***Make sure that no one, especially children, are near the vehicle.***

USING BIODIESEL (AK)

1. It is allowed to use 5% biodiesel fuel. If biodiesel fuel of higher ratio is used, the engine can be damaged and this will not be covered by warranty.
2. The biodiesel fuel should meet ASTM D6751, EN14214 and equivalent standards.
3. For details about biodiesel use, contact your **KIOTI** Dealer.

ADJUSTING BELT TENSION (AL)

The engine belt drives the alternator and coolant pump. If the tension of this belt is below the specification, the alternator efficiency decreases, resulting in insufficient battery charge level and low coolant circulation efficiency.

If the tension of this belt is too high, it wears rapidly and service life of the coolant pump bearing is shortened.

NOTE

- In this vehicle, the electric fan is not installed to the engine, but to the radiator under the hood.

1. Park the vehicle on level ground and apply the parking brake firmly.
2. Stop the engine and remove the engine inspection shield and seat cushion

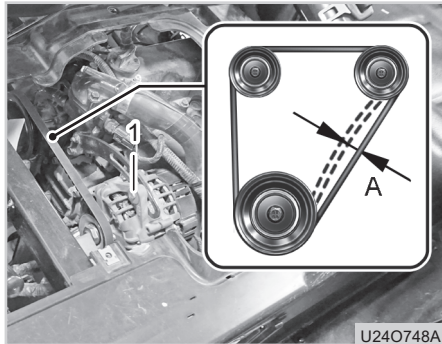

U240748A

(1) Adjusting Bolt
(A) Belt Tension

3. Loosen the adjusting bolt on the top of the alternator as well as the hinge bolt on the bottom of the alternator.
4. Leverage the alternator toward the outside.
5. Fix the upper adjusting bolt and push down the section A of the belt to measure the tension.

Standard Belt Tension (A)

1 in. (25 mm) when pressing center of belt

6. If necessary, loosen the adjusting bolt and make adjustment. Then, measure the tension again.
7. After adjustment, tighten the hinge bolt firmly. Check the adjusting bolt is tightened as well.

⚠ WARNING

- *If getting too close to rotating parts, such as the belt, during engine running, your clothes or part of your body can be caught.*

WASHING (AM)

It is recommended to wash your vehicle with water of moderate pressure and with or without soap. When washing your vehicle in a car wash, make sure high-pressure water is not directly sprayed to the following components:

⊕ IMPORTANT

- **Never spray high-pressure water to the radiator core, spark arrester, various warning decals, air cleaner inlet, CVT cover air inlet and outlet, key switch, instrument panel, air breather of gearbox and differential case, CV boots and steering rack boots, alternator, various wiring connections, electric sensors and switches.**



PROTECTING PLASTIC AND PAINTED SURFACE (AO)

Do not wipe any plastic parts if they are not washed.

Spraying insecticide can damage the plastic and painted surface. Never spray insecticide near the vehicle.

Do not spill brake fluid on the vehicle parts. It can damage the painted surface. If the brake fluid is spilled, wipe it immediately.

Never spill fuel on the vehicle components. It can damage the surface. If it is spilled, wipe it immediately.

CHECKING HYDRAULIC OIL (AP)



U45O720B

(1) Hydraulic Oil Tank

1. Park the vehicle on level ground and apply the parking brake firmly.
2. Unscrew the mounting bolts of the inspection shield from under the seat cushion.

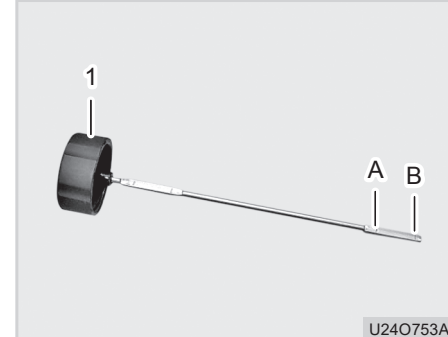

U24O753A

(1) Oil Dipstick
(A) MAX Limit

(B) MIN Limit

3. Pull out the hydraulic oil dipstick and wipe it clean.
4. Insert the dipstick into the end, and then pull it out to check the engine oil level.
5. If the oil level is below the MIN limit, add some oil.

Oil Capacity

2.64 U.S Gal. (10 L)



CLEANING AIR CONDITIONER CONDENSER (AQ)

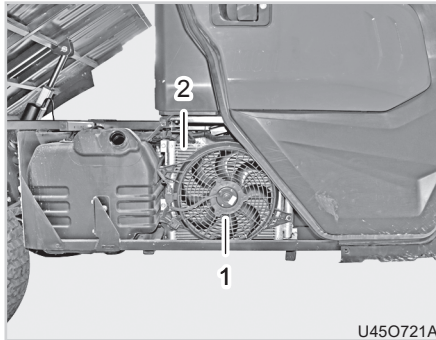

(1) Cooling fan (2) Condenser

1. Remove the cover on the lower right of the loading box.
2. After disconnecting the connector of the cooling fan, use a wrench to remove the cooling fan. Clean the condenser and reassemble it.

⚠ CAUTION

- **Make sure to stop engine when checking. If cooler fan is blocked by dirt, clean with a soft brush or cloth using water.**

CHECKING REFRIGERANT (AR)

If the refrigerant is insufficient, the performance of the air conditioner is deteriorated. Also, charging the air conditioner with excessive refrigerant affects its performance. Therefore, have the system checked by your local **KIOTI Dealer** if a malfunction is found.

⚠ CAUTION

- **Park UTV on a flat place and chock the wheels.**
- **Put forward/backward lever, Main shift lever and PTO lever in neutral.**

⚠ WARNING

- ***Only qualified service personnel should service the air conditioner as its refrigerant is under high pressure. An injury can occur.***

AIR CONDITIONER MAINTENANCE (AS)

Make sure to follow the instructions below to keep the air conditioner in the best condition:

1. Operation in winter season:

During the winter time, run the air conditioner once or twice every month to prevent refrigerant leakage and corrosion in the air conditioner system and to facilitate oil circulation in the compressor in order to prevent malfunction.

The A/C does not operate when the air temperature is below 2°C. Therefore, warm the inside air by operating the heater in order to be able to operate the A/C.

2. Air conditioner condenser care:

If there is foreign material in the A/C condenser and engine radiator, their cooling performance may be deteriorated. Therefore, always keep them clean for their optimal cooling performance. When cleaning the core of the condenser, use a soft brush and water. Carefully clean the condenser so as not to bend it.



3. Operation in summer season:

Make sure to check the tension of the A/C belt before using the A/C frequently.

⚠ CAUTION

- The A/C system is charged with new refrigerant that does not destroy the ozone layer. Be careful when servicing the A/C system.
- Do not use unspecified refrigerant and compressor oil, or the air conditioner system could be seriously damaged.
- The performance of the A/C becomes poor when the refrigerant is insufficient. However, charging the air conditioner with excessive refrigerant also affects its performance negatively. Therefore, have the system checked by a KIOTI Dealer if malfunction is found.

SPECIFICATIONS FOR A/C REFRIGERANT AND LUBRICANT

Item	New refrigerant	Compressor oil
Type	R-134a	UCON488
Charging amount	0.6 kg (1.32 lbs.)	265cc (0.07 U.S.gal.)

⚠ WARNING

- *Have the air conditioner serviced by qualified service personnel. If it is serviced by an unqualified person, he/she can be injured by the refrigerant under high pressure.*

REPLACING A/C FILTER(AT)



(1) Hood

1. Park the vehicle on level ground and apply the parking brake firmly.
2. Open the hood.

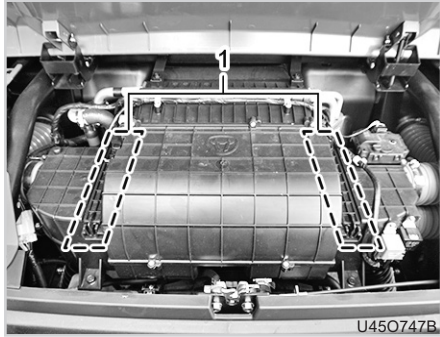

(1) A/C Filter Cover

3. Remove the A/C Filter Cover.

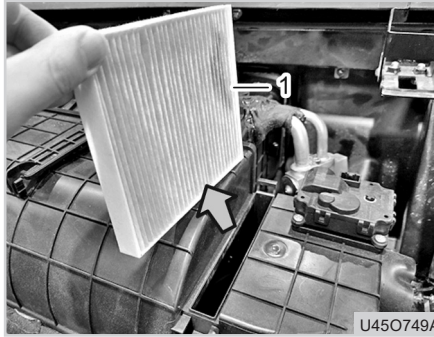

(1) Contaminated Filter

4. Remove the contaminated filter and replace it with a new one.

AIR CONDITIONER BELT TENSION (AU)

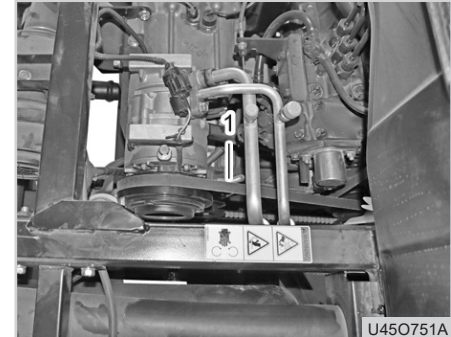

(1) A/C Belt

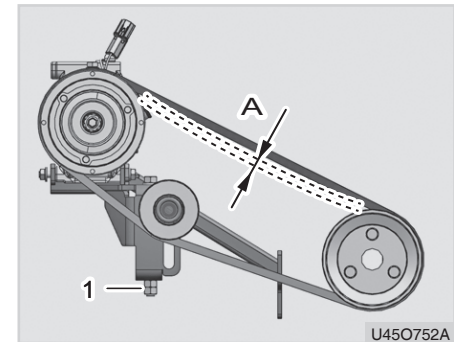

(1) Adjusting Bolt
(A) Adjusting Belt Tension



1. Stop the engine and apply the parking brake.
2. Press the belt between the pulley with force of 9.92 lbs. (4.5 kgf) and adjust the belt tension according to the below specification.

Tension of air conditioner belt (A)

When press the middle point of the belt :
0.39 in. (10 mm)



STORAGE AND DISPOSAL

VEHICLE STORAGE 8-2
 DAILY STORAGE8-2
 LONG-TERM STORAGE8-2
 USING VEHICLE AFTER LONG-TERM STORAGE.....8-3
DISPOSAL 8-4

8

8



VEHICLE STORAGE DAILY STORAGE

1. Keep the vehicle clean when it is stored. Make sure to wash it after work.
2. Store it indoors if possible. If it should be kept outside, cover it.

WARNING

- *When operating the vehicle in an enclosed area, ventilate the area to release exhaust gas to the outside. The exhaust gas is colorless and not visible, but is harmful.*
- *In an area that exhaust gas can come in contact with a flame or spark, do not store the vehicle with fuel in its fuel tank. Cool down the engine sufficiently before covering the vehicle with a protective cover.*

3. Remove the battery from the vehicle in winter and store it indoors.
4. Add anti-freeze to the vehicle in winter season in order to prevent the radiator from freezing.
5. Remove the ignition key and store it separately.

LONG-TERM STORAGE

Follow the instructions below if the vehicle is not to be used for a long period of time. This is to operate the vehicle again with minimum preparation after long-term storage.

IMPORTANT

- **If the vehicle is not used for an extended period of time, follow the instructions below to prevent corrosion and performance deterioration of the vehicle while it is stored.**

1. Check the bolts and nuts for looseness, and tighten if necessary.
2. Apply grease to areas where bare metal can rust.
3. Repair worn or damaged parts. Replace parts as necessary.
4. Inflate the tires to a pressure a little higher than usual.
5. Remove the battery from the vehicle. Store the battery according to the applicable storage instructions.

6. Keep the vehicle in a dry place where the vehicle is sheltered from rain. Cover the vehicle.
7. The vehicle should be stored in an enclosed area to avoid direct sunlight or heat. Make sure the tires are not exposed to sunlight and heat directly.
8. Keep the vehicle, including the engine components, clean.
9. Apply grease to every grease fitting as needed.
10. Apply grease to the exposed cylinder rod (if equipped with the dumping kit).
11. Check the coolant condition. If necessary, drain and flush it, and then refill with anti-freeze and water. **KIOTI** recommends a 50/50 mix.
12. Set the shift lever to the neutral position.
13. Attach a tag onto the vehicle to inform the storage condition of the vehicle.



14. If the machine is being operated with Bio-diesel, drain the bio-diesel and fill the standard diesel to run the engine for more than 30 minutes before the long term storage. (More than 90 days)

IMPORTANT

- **When cleaning the vehicle, be sure to stop the engine. Allow sufficient time for the engine to cool before cleaning.**
- **Cover the vehicle after the muffler and engine is cooled down.**
- **The battery should be recharged every 90 days while it is stored.**
- **Store the vehicle in a dry and protected place. If the vehicle should be kept outside, cover it with a water-proof cover.**

USING VEHICLE AFTER LONG-TERM STORAGE

1. Check the tire inflation pressure and inflate the tires if they are low.
2. Install the battery to the vehicle. Check that the battery is fully charged before installation.
3. Check the tension of the fan belt.
4. Check all fluid levels, including the engine oil, gearbox oil, front/rear differential case oil, engine coolant and brake fluid.
5. Remove grease from the exposed cylinder rod.
6. Apply grease to the lubrication points, and grease fitting as needed.
7. Check if the instrument cluster and all parts operate correctly while running the engine for a few minutes.
8. Drive the vehicle outside and test the vehicle's brake operation, shift operation, high-speed, low-speed and reverse driving, and parking brake operation for normal operation.
9. Stop the engine and check for oil leakage. Repair the vehicle as necessary.



CAUTION

- **If the battery is not to be removed, disconnect its negative terminal at least. The wiring can be gnawed by rodents, leading to a fire.**



8-4 K9 2400SW(C,F)/K9 2400(D)C/K9 2400F

DISPOSAL

In order to protect the environment, use and dispose of the vehicle keeping the following in mind:

1. When changing the oil or coolant by yourself, be careful not to spill it and dispose used oil and coolant properly according to the applicable regulations.
2. Never leave or discard the expired vehicle, but contact your local **KI-OTI** Dealer to dispose it according to the regulations.



TROUBLESHOOTING

VEHICLE TROUBLESHOOTING..... 9-2

9

9



This troubleshooting chart summarizes simple service items for users who are familiar with mechanical systems. For more detailed service items, contact your local **KIOTI** Dealer.

VEHICLE TROUBLESHOOTING

Problem	Check item	Maintenance code
1. Start motor cannot run or run at low speed	• Blown main fuse (slow-blow fuse: near start motor cable)	AG
	• Loose battery cable	AD
	• Discharged battery (alternator malfunction)	AD
	• Key switch malfunction, Hard to start the engine	
2. Engine is hard to start (with start motor running)	• Insufficient preheating	
	• Malfunctioning electrical parts related to preheat operation such, as preheat relay, controller	
	• Extra manual preheating is required in extremely cold weather	
	• Insufficient fuel	
	• Air in fuel line, loose fuel line clamp or pinched fuel line	
	• Water or foreign material in fuel	
	• Clogged fuel filter or fuel hose, blocked fuel filter valve	L, M
	• Gelled fuel in extremely cold temperature (fuel for winter not used)	L, M



Problem	Check item	Maintenance code
2. Engine is hard to start (with start motor running)	• Fuel with low cetane used	
	• No operation of solenoid valve	
	• Injection pump malfunctioning	
	• Too high viscosity of engine oil (improper type of oil)	
	• Incorrect injection of injection nozzle or carbon accumulated onto it	N
	• Improper valve clearance	
3. Engine power is insufficient (knocking, vibration, smoke)	• Excessive engine oil (overfilling, water or hydraulic oil mixed with engine oil)	
	• Overheated engine	
	• Restricted fuel supply (clogged filter, water in fuel, loose fuel line, etc.)	M,L
	• Improper fuel, low cetane	
	• Clogged air cleaner	H
	• Improper injection timing	



Problem	Check item	Maintenance code
3. Engine power is insufficient (knocking, vibration, smoke)	• Poor injection nozzle condition or carbon accumulated onto it	
	• Improper valve clearance	
4. Engine is overheated	• Clogged radiator grille and core	O
	• Insufficient or leaking coolant (loose hose connection)	Q
	• Broken cooling fan	
	• Defected temperature sensor	
	• Improper mixing ratio of antifreeze	
	• Defected radiator cap	
	• Improper bleeding after coolant change	Q
	• Faulty cooling fan motor or switch	
	• Aged or faulty water pump	
	• Air in coolant line	Q
• Thermostat malfunction		



Problem	Check item	Maintenance code
4. Engine is overheated	<ul style="list-style-type: none"> Insufficient engine oil 	
5. Engine stops abruptly during operation	<ul style="list-style-type: none"> Insufficient fuel or clogged filter and hose 	H
	<ul style="list-style-type: none"> Air in fuel line or contaminated fuel 	
	<ul style="list-style-type: none"> Seizure due to overheated engine 	
5. Engine stops abruptly during operation	<ul style="list-style-type: none"> Engine oil leakage 	Q
	<ul style="list-style-type: none"> Coolant leakage 	Q
	<ul style="list-style-type: none"> Faulty solenoid 	
	<ul style="list-style-type: none"> Injection pump malfunctioning 	
6. Electrical device is malfunctioning (parts related to preheat, starting, illumination, horn, etc.)	<ul style="list-style-type: none"> Blown fuse 	AF, AG
	<ul style="list-style-type: none"> Improperly connected wiring 	
	<ul style="list-style-type: none"> Faulty relay and controller (in engine compartment) 	
	<ul style="list-style-type: none"> Discharged battery 	
7. Battery is discharged	<ul style="list-style-type: none"> Key switch left in the "ON" position 	



Problem	Check item	Maintenance code
7. Battery is discharged	• Electrical devices (headlamps, work lamps, turn signal lamps, etc) left "ON"	
	• Natural discharge due to no operation for a long period of time	
	• No charging due to faulty alternator, faulty alternator wiring connection	
	• Frequent repetition of engine start and stop (lack of time to charge)	
	• Excessive electricity use from external device (additionally attached device, such as implement)	
	• Prolonged cranking in severe condition	
	• Expired battery	
8. Vehicle cannot be driven	• Parking brake not released	AA
	• Shift lever not shifted.	AJ
	• Faulty CVT belt	J, K
9. Poor shift operation (HI-LO, 4WD)	• Improperly adjusted shift cable	AJ
	• Improperly adjusted 4WD cable	AJ
10. Vehicle cannot escape a pit or rough road	• Faulty 4WD shift operation	AJ



Problem	Check item	Maintenance code
10. Vehicle cannot escape a pit or rough road	<ul style="list-style-type: none"> Differential lock system malfunction (improperly adjusted differential lock cable) 	AI
11. Power is insufficient to drive uphill	<ul style="list-style-type: none"> Shift lever not in "L" position 	
	<ul style="list-style-type: none"> 4WD not used 	
	<ul style="list-style-type: none"> Worn CVT belt 	J, K
12. Vehicle cannot reach its max. speed	<ul style="list-style-type: none"> Worn CVT belt 	J, K
	<ul style="list-style-type: none"> Improperly adjusted accelerator pedal cable (engine cannot reach its full speed) 	
13. Braking force is insufficient	<ul style="list-style-type: none"> Wet brake 	
	<ul style="list-style-type: none"> Insufficient brake fluid 	X
	<ul style="list-style-type: none"> Air in brake line 	X
	<ul style="list-style-type: none"> Excessively worn brake pad 	Y, Z
14. Vehicle pulls to one side when braking	<ul style="list-style-type: none"> Wet brake pads on one side 	
	<ul style="list-style-type: none"> Excessively worn brake pads one side 	Z
	<ul style="list-style-type: none"> Air in brake line 	X



Problem	Check item	Maintenance code
15. Parking brake is malfunctioning (vehicle rolls down on slope)	• Improperly adjusted parking brake cable	AA
	• Worn parking brake pad	AA
16. Steering wheel feels heavy	• Insufficient inflation pressure of front tires	
	• Insufficient lubrication and contamination due to torn steering rack boots	W
17. Steering wheel is not operated smoothly	• Faulty steering knuckle	W
	• Improperly adjusted toe-in	
	• Excessive steering wheel play	
18. Hydraulic pressure is faulty (if equipped with dumping kit or auxiliary hydraulic kit)	• Lack of Hydraulic fluid in hydraulic tank	
	• Improper hydraulic oil used	
	• Faulty valve and pump	
19. Bad engine brake and belt noise (falling down slope)	• Use of engine brake in H-speed (high-speed gear)	
	• Overload and CVT belt wear	J, K

※ If you do not find the cause of trouble, consult your **KIOTI** dealer for assistance.



INDEX

INDEX..... 10-2

10

10

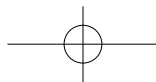



NUMERIC

2WD/4WD SHIFT LEVER.....4-31
 4WD OPERATION5-26

A

ACCELERATOR PEDAL4-27
 ACCESS FOR SERVICE7-8
 ADJUSTING BELT TENSION (AL).....7-46
 ADJUSTING SUSPENSION (AB).....7-37
 ADJUSTING THE TIME4-18
 AIR CONDITIONER BELT TENSION (AR).....7-51
 AIR CONDITIONER CONTROLLER.....4-44
 AIR CONDITIONER MAINTENANCE4-46
 AIR CONDITIONER MAINTENANCE (AP).....7-49
 AIR CONDITIONER SWITCH (AIR CONDITIONER) ...4-45
 ALIGNING WHEEL AND CHECKING WHEEL NUT (AH)....7-44
 APPLYING GREASE (D).....7-10

B

BATTERY (SEALED) (AD)7-38
 BATTERY CHARGING LAMP4-23
 BATTERY SWITCH7-40
 BELTS AND RUBBER PARTS6-3
 BLEEDING AIR IN COOLANT(Q2).....7-26

BLEEDING FUEL LINE (M).....7-20
 BRAKE PEDAL4-27
 BRUSH GUARD4-35

C

CABIN SYSTEM4-39
 CARGO BED4-36
 CARGO BED CONTROL SWITCH (IF EQUIPPED)4-14
 CAUTIONS FOR DECAL MAINTENANCE1-28
 CAUTIONS WHEN USING ELECTRIC POWER
 STEERING5-22
 CHANGING COOLANT (Q1).....7-23
 CHANGING ENGINE OIL AND FILTER (F)7-13
 CHARGING7-41
 CHECK ITEM5-2
 CHECKING AIR HOSE AND CLAMP(I)7-15
 CHECKING AND CHANGING FRONT AXLE OIL (T)7-29
 CHECKING AND CHANGING GEARBOX OIL (S).....7-27
 CHECKING AND CHANGING REAR AXLE OIL (U)7-31
 CHECKING AND REPLACING FUSE (AF)7-42
 CHECKING BRAKE FLUID (X).....7-34
 CHECKING BRAKE PAD (Z)7-35
 CHECKING BRAKE PEDAL FREE PLAY (Y).....7-34
 CHECKING COOLANT IN AUXILIARY COOLANT
 TANK (P)7-22



CHECKING CVT BELT (J).....	7-16	COMBINATION SWITCH.....	4-10
CHECKING CVT DRIVEN PULLEY CLUTCH BUT- TIONS (K).....	7-18	CONTROLS.....	4-26
CHECKING DIFFERENTIAL LOCK CABLE (AI).....	7-45	CONTROLS AND FEATURES.....	4-1
CHECKING DRIVE SHAFT AND CV BOOTS (V).....	7-32	COOLANT TEMPERATURE GAUGE.....	4-19
CHECKING ENGINE OIL LEVEL (E).....	7-12	COOLANT, BRAKE FLUID AND ELECTRICAL DE- VICES.....	4-38
CHECKING FUEL FILTER(L).....	7-19	CUP HOLDERS AND STORAGE BOXES.....	4-35
CHECKING HYDRAULIC OIL (AP).....	7-48	D	
CHECKING INJECTION NOZZLE AND FUEL INJEC- TION PUMP (N).....	7-21	DAILY CHECK CHART.....	7-3
CHECKING PARKING BRAKE (AA).....	7-36	DAILY INSPECTION.....	5-2
CHECKING REFRIGERANT (AR).....	7-49	DAILY INSPECTION.....	7-8
CHECKING SHIFT AND 4WD CABLES (AJ).....	7-45	DAILY STORAGE.....	8-2
CHECKING SPARK ARRESTER OF EXHAUST PIPE (IF EQUIPPED) (R).....	7-27	DECALS.....	1-24
CHECKING STEERING RACK BOOTS AND BALL JOINT (W).....	7-33	DIFFERENTIAL LOCK LEVER (REAR WHEEL).....	4-30
CHECKING SUSPENSION SHOCK ABSORBER (AC).....	7-38	DIFFERENTIAL LOCK OPERATION.....	5-27
CHECKING WARNING LAMPS AFTER STARTING ENGINE.....	5-5	DIRECTION FOR STORAGE.....	7-41
CIRCULATION OF INDOOR AIR AND INFLOW OF EXTERNAL AIR.....	4-48	DISPOSAL.....	8-4
CLEANING AIR CONDITIONER CONDENSER (AQ).....	7-49	DRAWBAR (IF EQUIPPED).....	4-6
CLEANING RADIATOR CORE (O).....	7-21	DRIVING BACKWARD.....	5-19
CLEANING THE VEHICLE.....	1-20	DRIVING IN FOREST.....	5-17
		DRIVING ON DOWNHILL ROADS.....	5-17
		DRIVING ON ROAD.....	5-19
		DRIVING ON SLIPPERY SURFACES.....	5-14



D

DRIVING ON SLOPE5-16
 DRIVING THROUGH WATER5-18
 DUST VALVE (G)7-14

E

ELECTRIC COOLING FAN MOTOR4-4
 ELECTRIC PARTS6-3
 EMERGENCY SITUATION1-21
 ENGINE CHECK LAMP4-23
 ENGINE INSPECTION4-37
 ENGINE OIL PRESSURE WARNING LAMP4-20
 ENGINE SERIAL NUMBER2-2
 ENTRANCE4-40
 ERROR CODE DISPLAY PRIORITY4-25
 ERROR INDICATOR4-25
 ESSENTIAL REPLACEMENT PART6-2
 EXTERIOR DIMENSIONS3-2
 EXTERIOR VIEW4-3

F

FADE4-28
 FAN SPEED CONTROL DIAL4-45
 FILTERS6-2

FRONT HITCH RECEIVER (IF EQUIPPED)4-5
 FRONT WINDOW4-40
 FUEL GAUGE4-19
 FUEL TANK4-36

G

GENERAL PRECAUTIONS1-2
 GENERAL SPECIFICATIONS3-3
 GLOW PLUG INDICATOR4-23

H

HAND THROTTLE LEVER (OPTION)4-37
 HAZARD LAMP SWITCH4-12
 HEAD LAMP SWITCH4-10
 HEAD LIGHT HIGH BEAM LAMP4-21
 HEADLAMP4-5
 HEADLAMP SWITCH4-13
 HEADREST (IF EQUIPPED)4-33
 HEATER AND AIR CONDITIONER4-44
 HEATER CONTROLLER (K9 2400F)4-44
 HILL INCLINED SIDEWARD5-16
 HOOD4-4
 HORN SWITCH4-12
 HOURMETER, ODOMETER4-18



HOW TO DRIVE.....	5-7
HOW TO WARM UP ENGINE.....	5-10

I

IMPLEMENTS AND ATTACHMENTS	1-21
INDEX.....	10-1
INDOOR LAMP	4-42
INSIDE REAR VIEW MIRROR (IF EQUIPPED).....	4-43
INSTRUMENT PANEL.....	4-17
INTERIOR DEVICES.....	4-39

J

JUMP START	5-11
------------------	------

K

KEY SWITCH.....	4-8
-----------------	-----

L

LONG-TERM STORAGE.....	8-2
LOWER FUEL LEVEL WARNING INDICATOR	4-24
LUBRICANTS	7-6

M

MAIN FUSE (SLOW-BLOW FUSE) (AG)	7-44
---------------------------------------	------

MAINTENANCE	7-1
MAINTENANCE CHECK LIST.....	7-3
MAINTENANCE INTERVAL TABLE	7-4
MODE SELECTION BUTTON	4-18
MOUNTING LOCATION	1-22

N

NEUTRAL INDICATOR	4-22
NOISE LEVELS AS PERCEIVED BY THE OPERATOR	3-8

O

OILS AND FLUID	6-2
OPENING INSPECTION SHIELD (A)	7-8
OPENING SEAT CUSHION (B)	7-9
OPERATING PRINCIPLE OF PREHEAT SYSTEM.....	5-6
OPERATING THE ENGINE	5-2
OPERATING THE VEHICLE.....	5-7
OPERATION	5-1
OPTION LIST AND FEATURES	3-6

P

PARKING.....	5-13
PARKING BRAKE INDICATOR	4-21
PARKING BRAKE LEVER	4-29



P

PASSENGER SEAT.....4-33
 PRECAUTIONS BEFORE OPERATION.....1-2
 PRECAUTIONS BEFORE OPERATION.....2-1
 PRECAUTIONS DURING OPERATION1-4
 PRE-OPERATION5-2
 PROPER INFLATION PRESSURE4-50
 PROTECTING PLASTIC AND PAINTED SURFACE
 (AO)7-48

R

RAISING CARGO BED (C).....7-9
 REAR HITCH RECEIVER.....4-6
 REFLEX REFLECTOR.....4-7
 REPLACEMENT PARTS6-1
 REPLACING A/C FILTER(AQ).....7-50
 REPLACING AIR FILTER (H)7-15
 REPLACING FUEL FILTER7-19
 REPLACING HEADLAMP BULB (AE)7-42
 ROPS4-34

S

SAFETY DECAL1-22
 SAFETY PRECAUTIONS1-1

SAFETY PRECAUTIONS DURING SERVICING.....1-15
 SAFETY PRECAUTIONS WHEN USING THE ROPS...1-19
 SEAT4-31
 SEAT BELT4-32
 SEAT BELT WARNING LAMP (IF EQUIPPED).....4-22
 SHIFT LEVER4-26
 SHIFTING.....5-14
 SKID PLATES (STEEL) (IF EQUIPPED)4-35
 SPARE SWITCH PANEL4-15
 SPECIFICATION.....3-2
 SPECIFICATIONS3-1
 SPECIFICATIONS FOR A/C REFRIGERANT AND
 LUBRICANT.....4-47
 SPEEDOMETER.....4-17
 STARTING THE ENGINE.....5-2
 STOPPING5-12
 STOPPING THE ENGINE5-6
 STORAGE AND DISPOSAL8-1
 SUN VISOR (IF EQUIPPED)4-42
 SUSPENSION.....4-5
 SWITCHES.....4-8

T

TAILGATE (BACK DOOR).....5-28



TEMPERATURE CONTROL SWITCH (AIR CONDIT-
TIONER).....4-45

TEMPERATURE CONTROL SWITCH (HEATER)4-47

TIRE4-48

TOWING TRAILER5-24

TRANSPORTING5-25

TRANSPORTING CARGO.....5-20

TROUBLESHOOTING9-1

TURN SIGNAL LAMP4-20

TURN SIGNAL LAMP SWITCH.....4-11

TURNING5-15

U

UNLOADING5-23

UPHILL AND DOWNHILL.....5-16

USB PORT & POWER SOCKET4-15

USING BIODIESEL (AK)7-46

USING VEHICLE AFTER LONG-TERM STORAGE8-3

V

VEHICLE IDENTIFICATION NUMBER.....2-2

VEHICLE SERIAL NUMBER2-2

VEHICLE STORAGE8-2

VEHICLE TROUBLESHOOTING9-2

VENT4-42

VIBRATION LEVELS OF THE UTV EXPOSITION TO
VIBRATIONS3-8

W

WARMING UP5-10

WASHING (AM).....7-47

WHEN DRIVING THE VEHICLE1-6

WHEN PARKING THE VEHICLE1-14

WHEN STARTING THE ENGINE1-4

WIPER4-41

WORKING LIGHT4-13

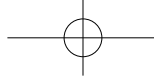

 **WARNING**

Breathing diesel engine exhaust exposes you to chemicals known to the State of California to cause cancer and birth defects or other reproductive harm.

- Always start and operate the engine in a well-ventilated area.
- If in an enclosed area, vent the exhaust to the outside.
- Do not modify or tamper with the exhaust system.
- Do not idle the engine except as necessary.

For more information go to www.P65warnings.ca.gov/diesel

UD27-7115