



NX Series

45 - 60 HP



NX SERIES

**EVERYTHING YOU NEED TO MAKE
HARD WORK SEEM EASY.**

Powerful? Check. Fuel-efficient? Check. All around awesome? Check. If you're looking for a 45 to 60 hp workhorse that'll get it done in style, we present you with the NX Series.

**Cab & ROPS Models
Synchro Shuttle or HST
Loaded with Features**

**Daedong® ECO Engine Technology
Hydraulic Independent PTO
Cruise Control (HST Models)**



Anti-Stall Function (HST Models)

When the "Anti-Stall function" is engaged, the tractor will protect itself from instant engine stall when there is momentary engine overload.

Single Lever Joystick

Front end loader work is made easier by the use of a single lever joystick. The lever returns to neutral when released. A float position allows the bucket free flotation over the ground surface.

Hydraulic Independent PTO

The standard rear PTO is easily engaged by the simple turn of a knob. A safety interlock prevents the engine from starting when the PTO switch is left on. All models come standard with a selectable manual or automatic PTO option. When the Auto PTO is engaged, the PTO will automatically shut off when the 3-point control is raised, eliminating exposure to the running implements.

Eco-Friendly Diesel Engine

The Common Rail Diesel Engine (CRDI) improves fuel efficiency while reducing noise levels. With this eco-friendly Tier 4 engine, the NX Series offers the operator a quiet work environment with powerful performance.

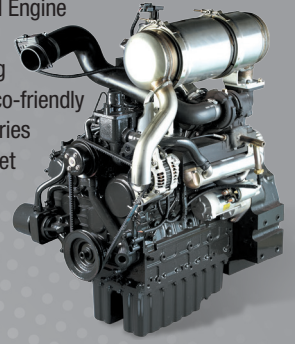

THE FUEL EFFICIENT AND RUGGED KIOTI NX SERIES



Fully-Featured HST Models

Featuring a performance proven, heavy duty HST drive, HST models deliver power smoothly and efficiently. The three range transmission (Hi/Mid/Low) with twin pedal operation, anti-stall function, cruise control and customizable response makes your job easier, smoother and safer.



Deluxe Suspension Seat

Ergonomically designed, adjustable suspension seat allows the operator to ride in comfort no matter what the task may be. A seat pocket on the back of cab models allows easy access for the operator's manual.



Ergonomic Joystick Lever

An ergonomically designed joystick lever for front loader operation is standard on NX Series tractors.

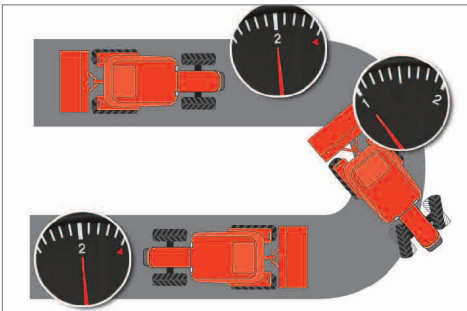

Turn Assist Control

The optional Turn Assist Control kit will drop the engine rpm by 10% automatically when turning sharply. This feature prevents the need to throttle down when turning at the end of a row as the unit will do this automatically.



Projection Head and Working Lamp

With LED projection head and working lamps, the operator will experience safer and easier operation in low light conditions.

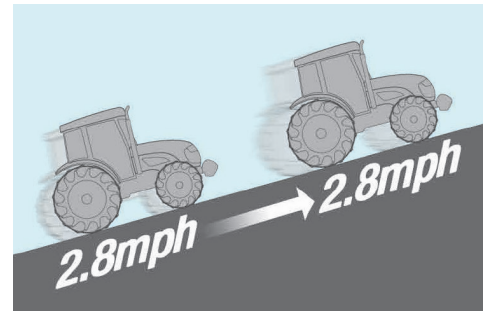

True Speed Cruise Control

The electronic HST control system enables the tractor to maintain a set speed in various ground and load conditions. This is a very useful feature for work requiring a set speed for precise coverage or application.



HST Linked Pedal

When the HST linked pedal is engaged, the HST pedal and the engine rpm is synchronized. This reduces fuel consumption and simplifies tractor operation for a variety of utility and loader applications.

3-Point Hitch with Telescopic Lower Links & Stabilizers

Standard telescopic lower link ends and stabilizers allow the operator to easily connect & adjust a wide variety of 3-point implements. The standard rear 3-point control lever easily raises and lowers the lift arms from outside the tractor when attaching implements.



Deluxe Cab with Panoramic View

The comfortable cab interior minimizes operator fatigue even after a long work day. The large unobstructed windows provide a panoramic view for increased sight lines.

Window Wiper

On cab models, the standard window wiper (rear optional) keeps the window free from rain and dust without blocking the operator's view.

Power Steering with Tilt

Hydrostatic power steering minimizes the effort required to make tight, repetitive turns. The steering wheel tilts with the simple push of a lever, allowing easy adjustment to fit operator needs.

Automotive Style Light Control Lever

An automotive style access lever controls headlights, horn and turn signals. Located on the side of the steering column for ease of access.

Air Conditioning System

The Cooling and Heating system, in cab models, will ensure comfortable working conditions for the operator year round.





Front End Loader

The KIOTI KL6010 front end loader is specifically designed for the NX Series tractors, providing efficient performance with single lever joystick control. The KIOTI loader, with a built-in parking stand, is designed to be quickly and easily attached and detached. KL Series loaders utilize the tractor's hydraulic system, feature single-lever control with float and come with a bucket level indicator.

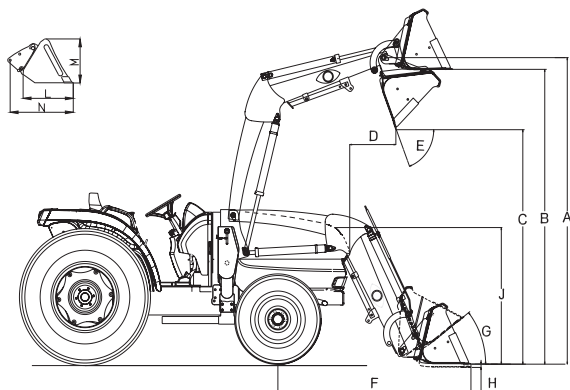

Loader Specifications

MODEL	L6010		
A Maximum Lift Height to Pivot Pin	108.3 in. (2,750 mm)		
B Clearance w/ Bucket Level	103.9 in. (2,639 mm)		
C Clearance w/ Bucket Dumped	82.7 in. (2,101 mm)		
D Reach at Maximum Height	19.7 in. (500 mm)		
E Maximum Dump Angle	66°		
F Reach w/ Bucket on Ground	70.9 in. (1,801 mm)		
G Maximum Rollback Angle	31°		
H Digging Depth Below Grade	8.5 in. (216 mm)		
J Overall Height in Carry Position	49 in. (1,245 mm)		
L Bucket Depth (Inner Shell)	19.9 in. (505 mm)		
M Bucket Height	22.8 in. (579 mm)		
N Bucket Length (Pivot Pin)	25.9 in. (658 mm)		
Lift Capacity to Full Height at Pivot Pins	2,761 lbs. (1,252 kg)		
Bucket Rollback Force at Ground Line	2,990 lbs. (1,356 kg)		
Breakout Force at Pivot Pins	3,727 lbs. (1,691 kg)		
Relief Valve Setting (Loader Control Valve)	2,556 psi		
Rated Flow (Tractor System)	10 gpm (37.9 L/min)		
Bucket Size (QA)	72 in.		
Bucket Capacity (Heaped)	13.06 ft³		
Approximate Weight (With Bucket)	1,267 lbs. (575 kg)		
Cycle Times	1,500 rpm	2,000 rpm	2,600 rpm (Full)
Raise Boom Frame	7.8 sec	6.1 sec	4.5 sec
Lower Boom Frame	4.8 sec	3.8 sec	2.8 sec
Dump Bucket	7.6 sec	5.5 sec	4.1 sec
Rollback Bucket	5.4 sec	4.2 sec	3.0 sec

Backhoe

The KIOTI KB2485 backhoe lets you trench up to 94.4 inches deep with a bucket dig force up to 3,748 pounds. The KB2485 backhoe feature subframe mounting, responsive two-lever controls with exceptional feathering, hydraulic stabilizers, transport lock and a variety of standard and heavy-duty buckets.

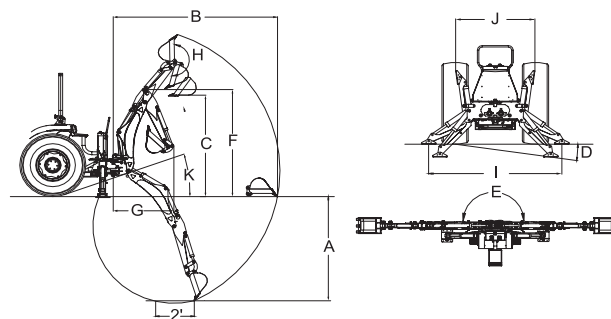

Backhoe Specifications

MODEL	KB2485
A Digging Depth (Two Foot Flat Bottom)	94.4 in. (2,400 mm)
B Reach from Center Line of Swing Pivot	136.1 in. (3,460 mm)
C Loading Height (Bucket at 60°)	80.3 in. (2,040 mm)
D Maximum Leveling Angle	10°
E Swing Arc	180°
F Transport Height (Maximum)	92.9 in. (2,360 mm)
G Transport Overhang	50.4 in. (1,280 mm)
H Bucket Rotation	180°
I Stabilizer Spread (Down Position)	68.7 in. (1,745 mm)
J Stabilizer Spread (Up Position)	46.4 in. (1,180 mm)
K Angle of Departure	21°
Shipping Weight (Without Bucket)	1,102 lbs. (500 kg)
Bucket Digging Force	3,748 lbs. (1,700 kg)
Dipperstick Digging Force	2,205 lbs. (1,000 kg)
Operating Pressure	2,466 psi (170 bar)

Cylinders

Cylinder	Bore DIA	Retracted Length	Stroke	Rod DIA
Boom	2.75	25.04	15.20	1.57
Bucket	2.36	24.8	15.55	1.38
Dipperstick	2.75	27.87	19.88	1.57
Swing	2.36	15.67	8.78	1.38
Stabilizer	2.36	17.55	10.31	1.38

Buckets

Bucket	Teeth Quantity	Struck Capacity	Heaped Capacity	Shipping Weight
12" Bucket	3	1.01 cu. ft.	1.24 cu. ft.	56 lbs.
18" Bucket	4	1.56 cu. ft.	2.02 cu. ft.	70 lbs.
24" Bucket	5	2.11 cu. ft.	2.82 cu. ft.	94 lbs.
36" Bucket	6	2.78 cu. ft.	4.00 cu. ft.	114 lbs.

* Specifications and design are subject to change without notice.

* Specifications and design are subject to change without notice.

SPECIFICATIONS



MODEL	NX4510	NX4510C	NX4510H	NX4510CH	NX5010	NX5010C	NX5010H	NX5010CH	NX5510	NX5510C	NX5510H	NX5510CH	NX6010H	NX6010CH	
ENGINE															
Model	3F183T														
Type	3 Cyl., In-line Vertical, Water-cooled 4-cycle Turbo Diesel, CRDI														
Engine Gross	hp (kW)	45 (33.6)			50 (37.3)			55 (41)			60 (44.7)				
PTO	hp (kW)	37.6 (28)	33.9 (25.3)	41.8 (31.2)	38.9 (29)	46 (34.3)	43.1 (32.1)	48.3 (36)							
Displacement	cu. in. (cc)	111.4 (1,826)													
Rated Revolution	rpm	2,600													
Fuel Tank Capacity	US gal. (ℓ)	14.8 (56)													
DRIVE TRAIN															
Clutch	Dry Type Single Stage	None		Dry Type Single Stage		None		Dry Type Single Stage		None					
Transmission	Synchro Shuttle	Hydrostatic		Synchro Shuttle		Hydrostatic		Synchro Shuttle		Hydrostatic					
Speeds	24×24	3 Range		24×24		3 Range		24×24		3 Range					
Differential Lock	Rear Standard														
Brake	Wet Multi Disc														
PTO Type	Independent														
Rear PTO (Standard)	rpm	540													
Mid PTO (Optional)	rpm	2,000													
4WD Type	Hydraulic														
HYDRAULIC SYSTEM															
Pump	Gear														
Pump Capacity (Max. Flow Rate)	gpm (L/min)	16.5 (62.4)	17.9 (67.6)	16.5 (62.4)	17.9 (67.6)	16.5 (62.4)	17.9 (67.6)								
3-Point Hitch	Category I						Category I & II								
Maximum Lifting Capacity (24" aft. of hitch)	lb. (kg)	3,177 (1,441)													
Hydraulic Lift Control System	Position with Draft Control														
Number of Remote Valves	1 Standard (1 Optional)														
Steering	Hydrostatic Power Steering														
TIRE SIZE															
Front AG. (Turf, Industrial)	8-16 (29-12.5-15, 10-16.5)						9.5-16 (29-12.5-15, 10-16.5)								
Rear AG. (Turf, Industrial)	13.6-24 (21.5L-16.1, 14.9-24)						16.9-24 (21.5L-16.1, 17.5-24)								
TRAVELING SPEEDS															
Forward	mph (km/h)	0.11~15.71(0.17~25.28)	0~16.52(0~26.59)	0.11~15.71(0.17~25.28)	0~16.52(0~26.59)	0.12~17.35(0.19~27.93)	0~18.26(0~29.38)								
Reverse	mph (km/h)	0.09~13.96(0.15~22.46)	0~16.52(0~26.59)	0.09~13.96(0.15~22.46)	0~16.52(0~26.59)	0.11~15.42(0.17~24.82)	0~18.26(0~29.38)								
DIMENSIONS															
Overall Length (Includes 3-pt Hitch)	in. (mm)	139.6 (3,547)													
Overall Width (Minimum Tread)	in. (mm)	65.6 (1,665)						65.7 (1,669)							
Overall Height (From Top of ROPS/Cab)	in. (mm)	103.1(2,618)	94.1(2,390)	103.1(2,618)	94.1(2,390)	103.1(2,618)	94.1(2,390)	103.1(2,618)	94.1(2,390)	103.1(2,618)	94.1(2,390)	103.1(2,618)	94.1(2,390)		
Wheelbase	in. (mm)	75.6 (1,920)													
Min. Ground Clearance	in. (mm)	13.7 (350)						15.7 (400)							
Tread	Front (AG.)	in. (mm)	55.2 (1,352)						53.3 (1,355)						
	Rear (AG.)	in. (mm)	52.1 (1,324)						52.5 (1,324)						
Min. Turning Radius (with brake)	ft. (m)	9.81 (2.99)						9.97 (3.04)							
Weight with AG. Tires	lb. (kg)	3,978 (1,804.4)	4,342 (1,969.5)	4,000 (1,814.4)	4,309 (1,954.5)	3,978 (1,804.4)	4,342 (1,969.5)	4,000 (1,814.4)	4,309 (1,954.5)	4,209 (1,909.2)	4,562 (2,069.3)	4,198 (1,904.2)	4,529 (2,054.3)	4,198 (1,904.2)	4,529 (2,054.3)

* NOTE : Specifications and design are subject to change without notice.

STANDARD EQUIPMENT

- Hydrostatic Power Steering
- Rear Differential Lock
- Rear PTO
- Single Remote Hydraulic Valve
- Instrument Panel
- Wet Multi Disc Brakes
- Draft Control
- Joystick Valve
- Fixed Drawbar
- Adjustable Seat
- Headlights
- Safety Lights
- Front Wiper
- Parking Brake
- Cup Holder
- SMV Sign
- Air Conditioner (Cab models)
- Sun Visor (Cab models)
- Side View Mirror
- Power Socket (Cab models)
- Rear Defrost (Cab models)

OPTIONAL EQUIPMENT

- Second Remote Hydraulic Valve
- Front Weights
- Rear Weights
- 7 Pin Socket
- Turn Assist
- Locking Fuel Cap
- Canopy (ROPS models)
- CD Player (Cab models)
- Rear Wiper (Cab models)
- Rear View Mirror (Cab models)

ATTACHMENTS

- Front End Loader
- Backhoe
- Snow Blower
- Contact your local KIOTI dealer for available implements.



KIOTI Tractor Division
 DAEDONG - USA, INC.
 6300 KIOTI Drive, Wendell, NC 27591 USA
 Toll free 877-GO-KIOTI • Fax 919-374-5001
 Web www.KIOTI.com

